

“façon de venise[®]”

VENICE ITSELF



“façon de venise[®]”



SCOPRIRE IL MONDO,
DISEGNARE LA LUCE,

CREATING LIGHT, DISCOVERING THE WORLD

Describing and discovering new places and fantasies, light effects, colours and refractions: new Façon de Venise creations are from the very heart of Venice and its traditions, offering attractive contemporary style.

DISEGNARE LA LUCE,
SCOPRIRE IL MONDO

Raccontare e scoprire nuovi luoghi e fantasie,
giochi di luce, colori e rifrazioni:

dal respiro profondo di Venezia, delle sue storie,
ecco le nuove creazioni Façon de Venise,
per uno stile contemporaneo e coinvolgente.



INDEX

- 2_ 27** SEAHORSE
- 28_ 63** MISSTRASS
- 66_ 115** AQUA
- 116_ 141** LIMELIGHT
- 144_ 155** DRILL
- 156_ 165** MALMZI
- 166_ 189** CHANDELIER
- 190_ 213** BRICK
- 214_ 231** DISH
- 232_ 247** FV
- 250_ 265** CLAUDE
- 266_ 281** BLOOM



SEAHORSE

design romani sacconi architetti associati

SEAHORSE _ SO 2L/ SO 5L/ SO 8L
LAMPADARIO IN TESSUTO ELASTICO/
CHANDELIER IN ELASTIC FABRIC

DESIGN ROMANI SACCANI ARCHITETTI ASSOCIATI, 2013





SEAHORSE SO 8L
LAMPADARIO IN TESSUTO ELASTICO /
CHANDELIER IN ELASTIC FABRIC

DESIGN ROMANI SACCANI ARCHITETTI ASSOCIATI, 2013



SEAHORSE_ SO 8L
LAMPADARIO IN TESSUTO ELASTICO /
CHANDELIER IN ELASTIC FABRIC

DESIGN ROMANI SACCANI ARCHITETTI ASSOCIATI, 2013



SEAHORSE_ SO 5L
LAMPADARIO IN TESSUTO ELASTICO/
CHANDELIER IN ELASTIC FABRIC

DESIGN ROMANI SACCANI ARCHITETTI ASSOCIATI, 2013









SEAHORSE _ AP 1L/ AP 2L
LAMPADARIO IN TESSUTO ELASTICO/
CHANDELIER IN ELASTIC FABRIC

DESIGN ROMANI SACCANI ARCHITETTI ASSOCIATI, 2013



SEAHORSE AP 2L
LAMPADARIO IN TESSUTO ELASTICO /
CHANDELIER IN ELASTIC FABRIC

DESIGN ROMANI SACCANI ARCHITETTI ASSOCIATI, 2013



SEAHORSE_ SO 5L
LAMPADARIO IN TESSUTO ELASTICO /
CHANDELIER IN ELASTIC FABRIC





DESIGN ROMANI SACCANI ARCHITETTI ASSOCIATI, 2013





Struttura metallo cromato. Rivestimento in tessuto elastico sfoderabile e lavabile. Colori: bianco, marrone, argento, oro, verde, grigio, camouflage, avorio.

Chrome metal structure. Removable and washable elastic fabric covering. Colors: white, brown, silver, gold, green, grey, camouflage, ivory.

12W E14  
42W E14  

SEAHORSE AP 1L

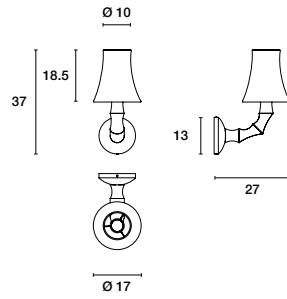

1 x   or 1 x  

SEAHORSE AP 2L

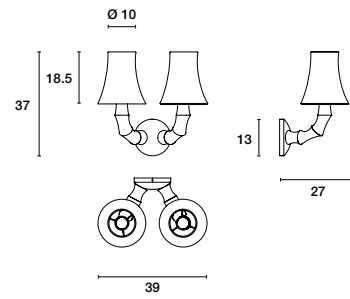

2 x   or 2 x  

SEAHORSE SO 2L

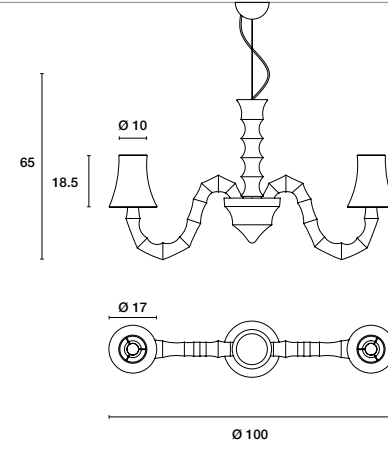

2 x   or 2 x  

SEAHORSE SO 5L

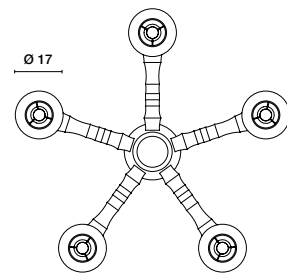
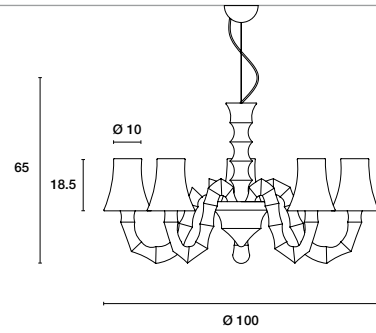

5 x   or 5 x  

SEAHORSE SO 8L

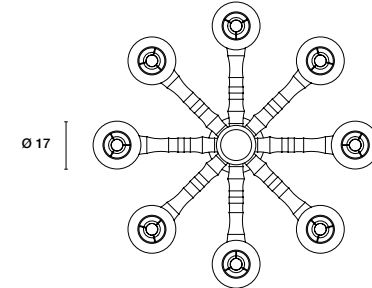
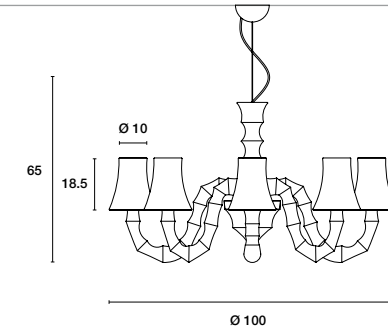

8 x   or 8 x  

SEAHORSE
table of contents



MISSTRASS

design mauro marzollo



**MISSTRASS_PL100,
PLAFONIERA MODULARE IN PMMA/
MODULAR CEILING LAMP IN PMMA**

DESIGN MAURO MARZOLLO, 2008

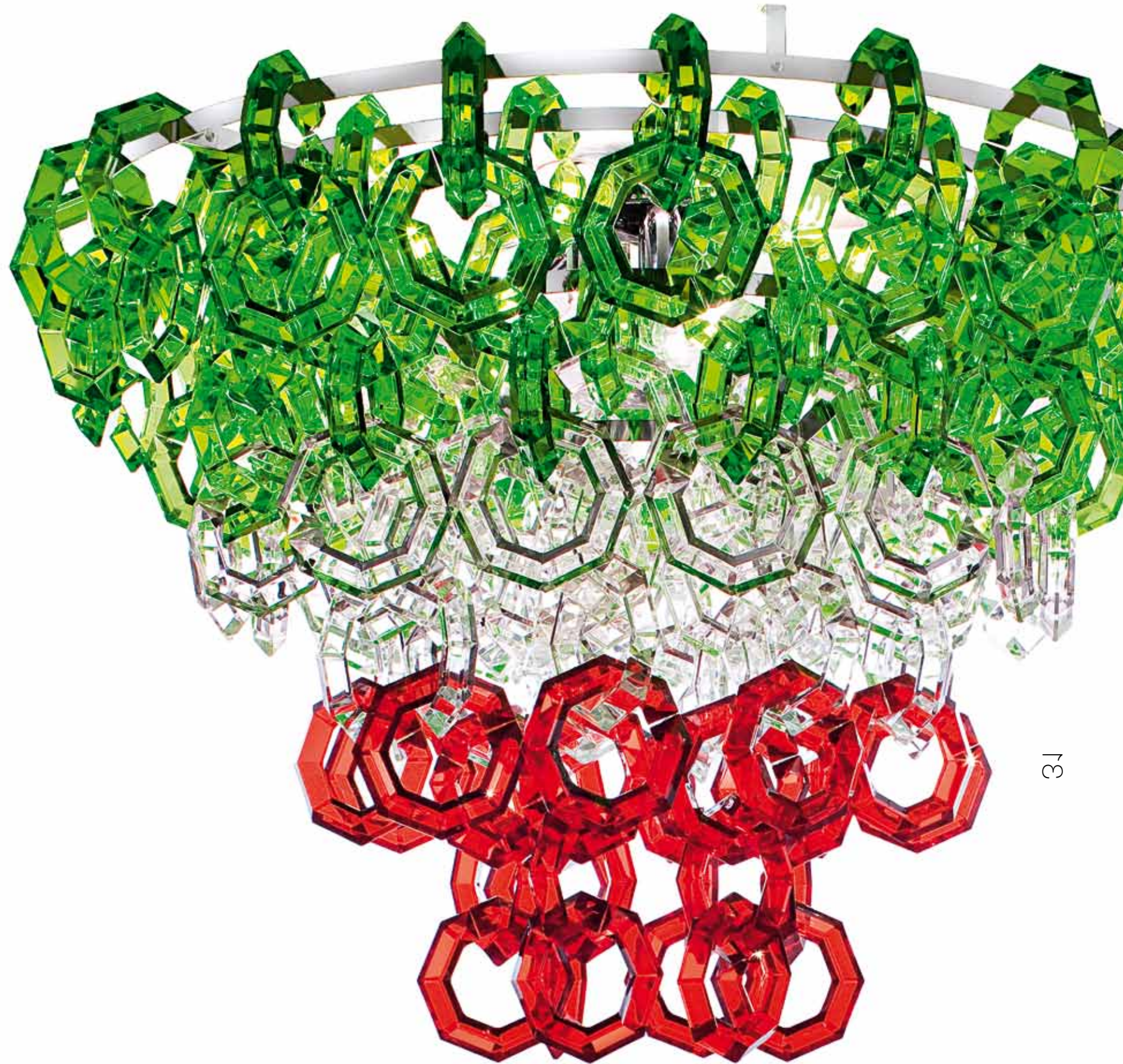

MISSTRASS_PL70 L
PLAFONIERA MODULARE IN PMMA/
MODULAR CEILING LAMP IN PMMA

DESIGN MAURO MARZOLLO, 2008







MISSTRASS_PL70
**PLAFONIERA MODULARE IN PMMA/
MODULAR CEILING LAMP IN PMMA**

DESIGN MAURO MARZOLLO, 2008

MISSTRASS _ SO 70 CUSTOM
SOSPENSIONE MODULARE IN PMMA/
MODULAR SUSPENDED LAMP IN PMMA

MISSTRASS _ AP CUSTOM
APPLIQUE MODULARE IN PMMA/
MODULAR WALL LAMP IN PMMA

DESIGN MAURO MARZOLLO, 2008





MISSTRASS_PL50 C
PLAFONIERA MODULARE IN PMMA/
MODULAR CEILING LAMP IN PMMA

DESIGN MAURO MARZOLLO, 2008

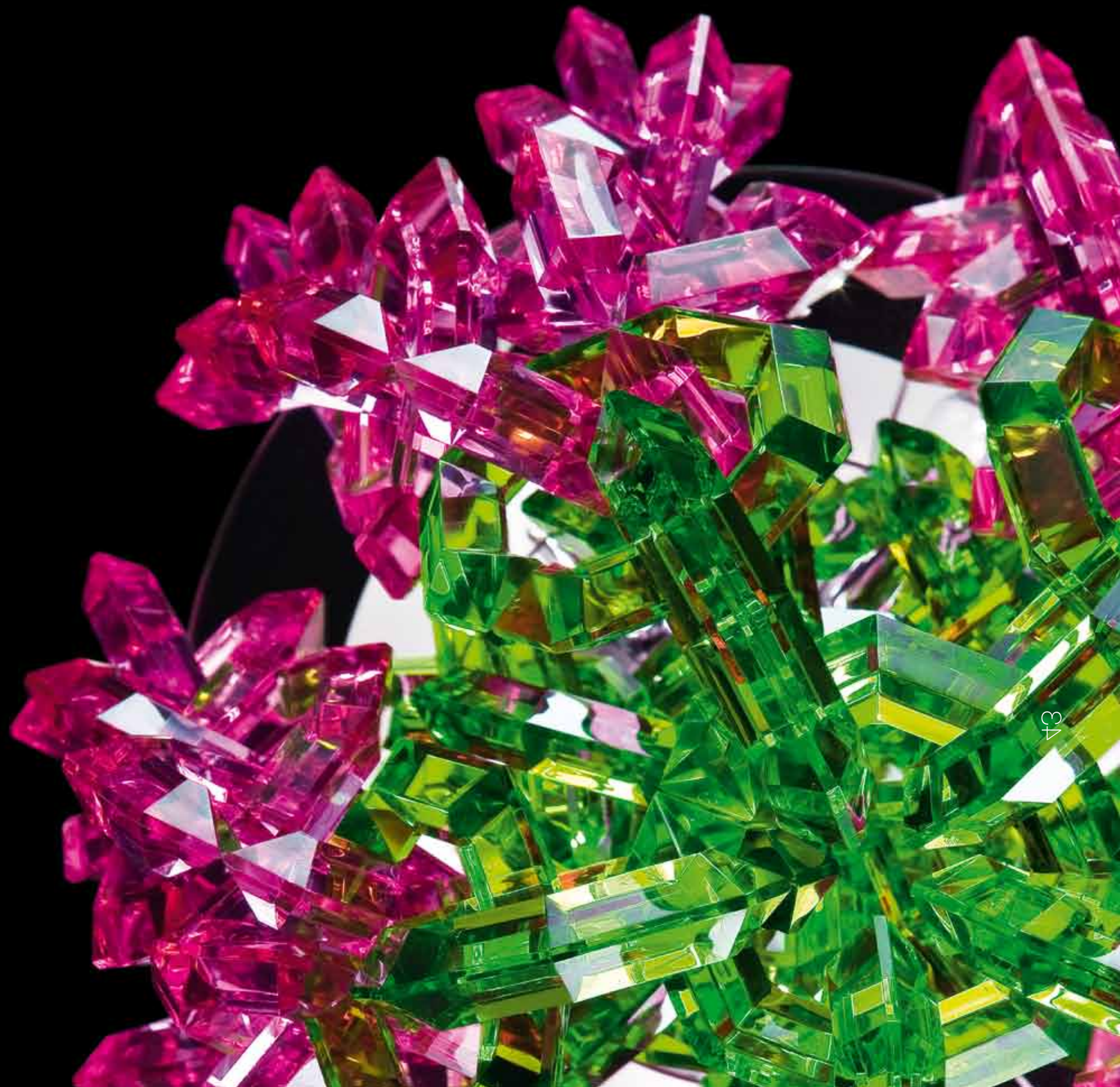



MISSTRASS _ SO 100
SOSPENSIONE MODULARE IN PMMA /
MODULAR SUSPENDED LAMP IN PMMA

DESIGN MAURO MARZOLLO, 2008



MISSTRASS_PL100
PLAFONIERA MODULARE IN PMMA/
MODULAR CEILING LAMP IN PMMA

DESIGN MAURO MARZOLLO, 2008





MISSTRASS _ SPHERE 70
SOSPENSIONE MODULARE IN PMMA /
MODULAR SUSPENDED LAMP IN PMMA

DESIGN MAURO MARZOLLO, 2011







MISSTRASS_50
SOSPENSIONE MODULARE IN PMMA/
MODULAR SUSPENDED LAMP IN PMMA

DESIGN MAURO MARZOLLO, 2008







60

FAÇON DE VENISE MISSTRASS

MISSTRASS AP
APPLIQUE MODULARE IN PMMA/
MODULAR WALL LAMP IN PMMA

DESIGN MAURO MARZOLLO, 2008



61

Diffusore realizzato con elementi componibili in pmma nei colori: cristallo, acquamarine, lampone, lime, carbone, miele, ciliegia. Montatura inox lucido.

Diffuser comprising modular elements in PMMA in the following colours: crystal, aquamarine, raspberry, lime, coal black, honey and cherry. Fixture in polished stainless steel.

- 40W E14
- 7W E14
- 100W E27
- 100W E27 HALOPAR 30
- 23W E27
- 20W E27
- 60W E14
- 60W E27
- 15W E27
- 30W E27 FLUOR
- 75W E27 INC

AP

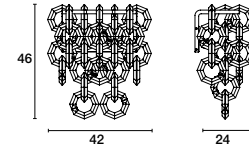

2 x or 2 x

PL 35

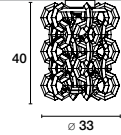

1 x or 1 x or 1 x

PL 35 L

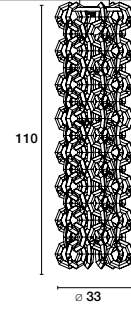

1 x or 1 x or 1 x

PL 50

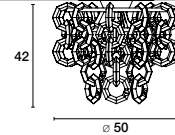

5 x or 5 x

PL 50 L

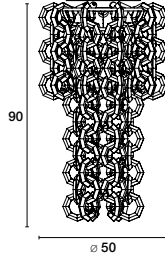

5 x or 5 x

PL 70

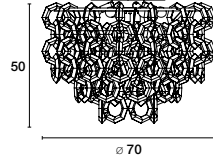

6 x + 3 x or 6 x + 3 x

PL 100

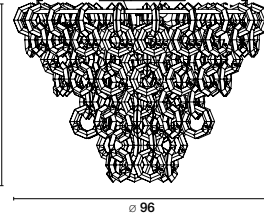

6 x + 3 x or 6 x + 3 x

SO 50

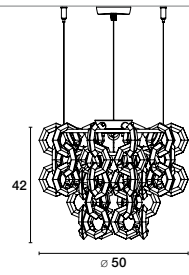

5 x or 5 x

SO 70

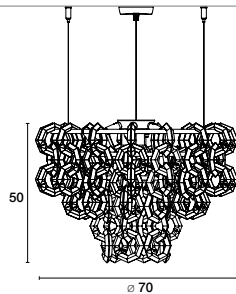

6 x + 3 x or 6 x + 3 x

SO 100

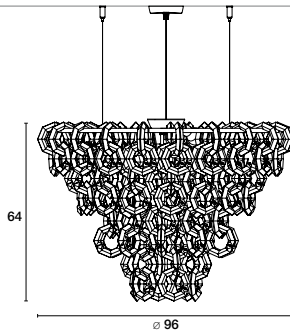

6 x + 3 x or 6 x + 3 x

SO

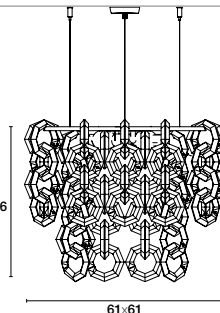

2 x or 2 x

SPHERE 50

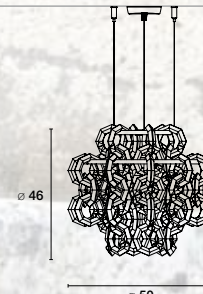

1 x or 1 x

SPHERE 70

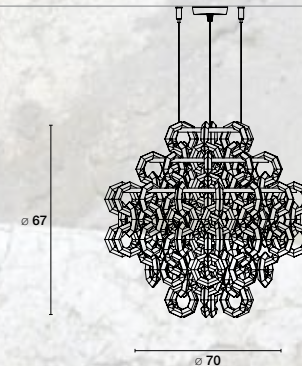

3 x or 3 x

SPHERE 100

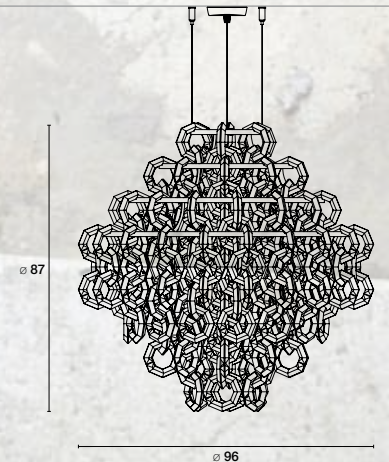

4 x or 4 x

BINARIO 1

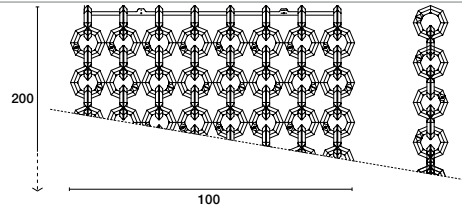

BINARIO 2

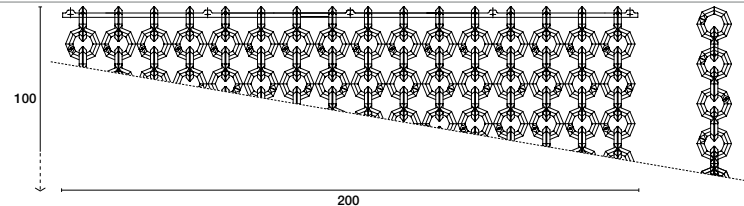

MISSTRASS
table of contents

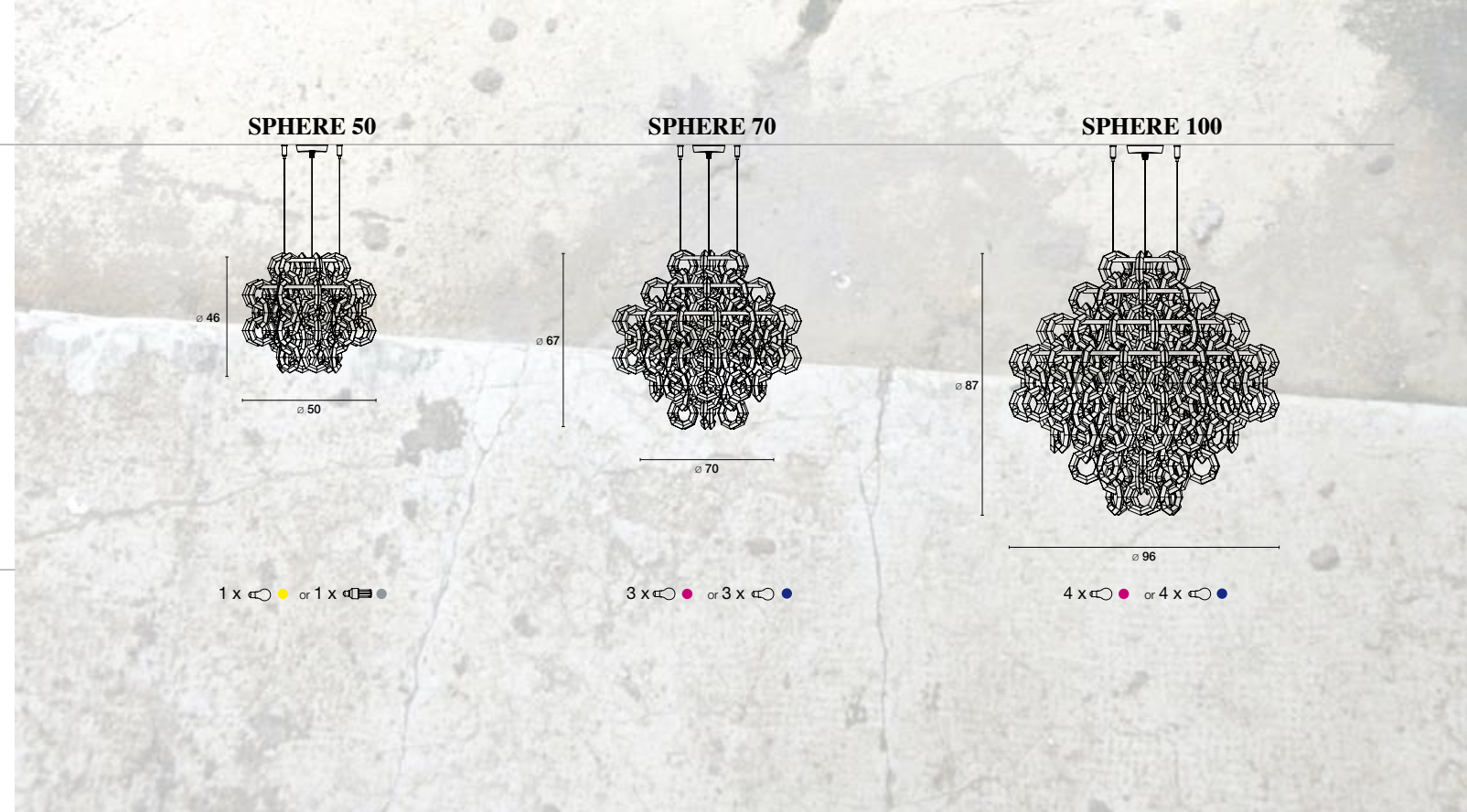

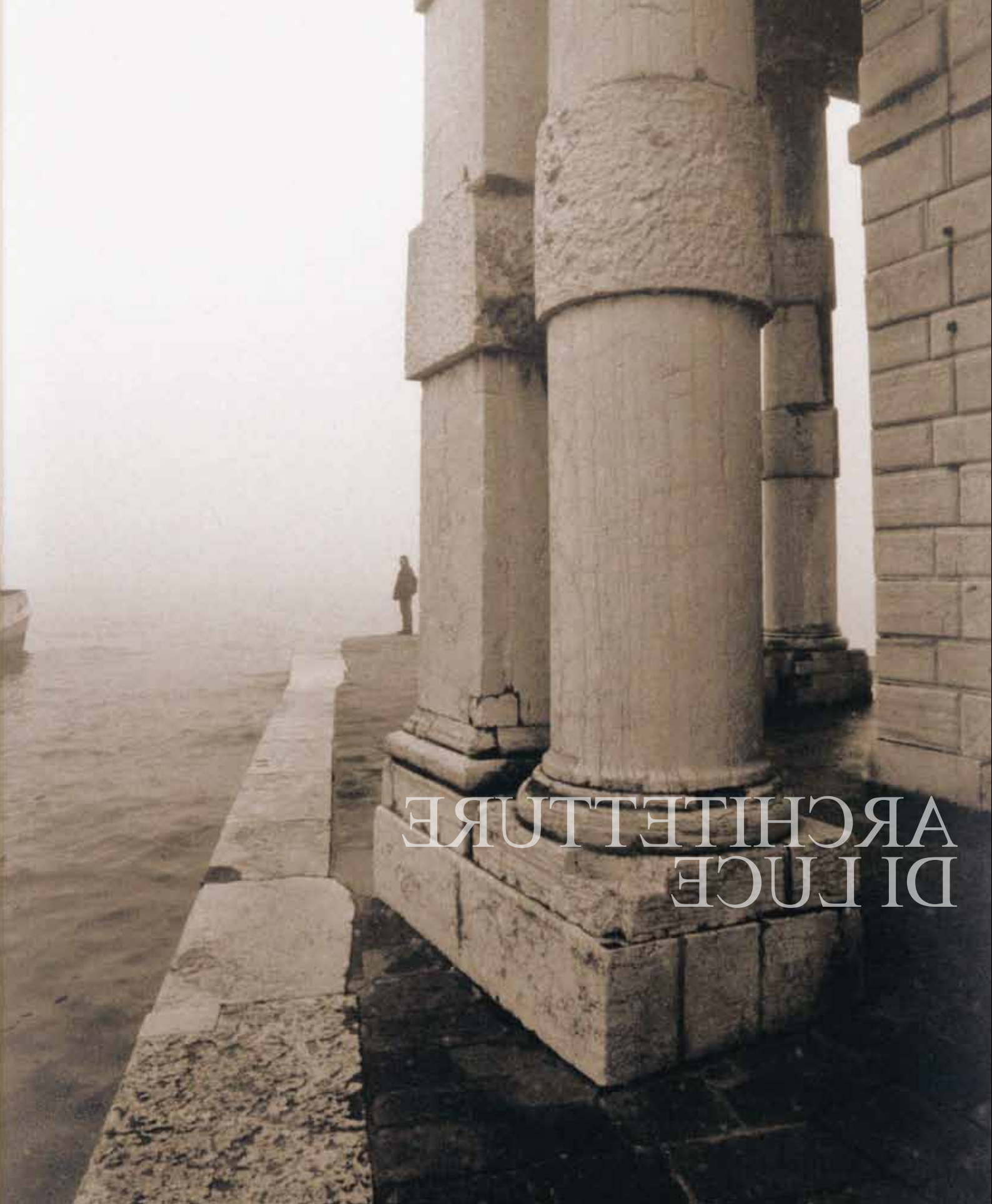

ARCHITECTURAL LIGHTING ELEMENTS

Contrasting light and shade, reflected landscapes, colours and global voices and silence in the fog: the most genuine atmospheres of the lagoon city inspire the contemporary path taken by Façon de Venise.

ARCHITETTURE
DI LUCE

ARCHITETTURE
DI LUCE

Contrasti di luci ed ombre, paesaggi di riflessi e mosaici dai mille colori, voci dal mondo e silenzi nella nebbia: dalle atmosfere più autentiche della città lagunare traggono ispirazione forme e colori che animano il percorso contemporaneo di Façon de Venise.



AQUA design brian rasmussen

AQUA _ SO L
COMPOSIZIONE MODULARE
DI PARALUMI IN TESSUTO /
MODULAR ARRANGEMENT
OF LAMPSHADES IN FABRIC

DESIGN BRIAN RASMUSSEN, 2010



AQUA _ SO 15L
COMPOSIZIONE MODULARE
DI PARALUMI IN TESSUTO/
MODULAR ARRANGEMENT OF LAMPSHADES IN FABRIC

DESIGN BRIAN RASMUSSEN, 2010





AQUA _ SO 91
COMPOSIZIONE MODULARE DI PARALUMI IN TESSUTO /
MODULAR ARRANGEMENT OF LAMPSHADES IN FABRIC

DESIGN BRIAN RASMUSSEN, 2010

PRIVATE HOUSE _ S. ELENA GARDENS / VENICE _ 10.25 AM



AQUA SO 9L
**COMPOSIZIONE MODULARE DI PARALUMI IN TESSUTO/
MODULAR ARRANGEMENT OF LAMPSHADES IN FABRIC**
DESIGN BRIAN RASMUSSEN, 2010





AQUA MAXI _ SO 1L UP
**ELEMENTO MODULARE CON PARALUME IN TESSUTO/
MODULAR ELEMENT WITH LAMP SHADES IN FABRIC**

DESIGN BRIAN RASMUSSEN, 2012



AQUA MAXI _ SO 5L
COMPOSIZIONE MODULARE DI PARALUMI IN TESSUTO /
MODULAR ARRANGEMENT OF LAMPSHADES IN FABRIC

DESIGN BRIAN RASMUSSEN, 2012

AQUA _ SO 20 CUSTOM
COMPOSIZIONE MODULARE DI PARALUMI IN TESSUTO/
MODULAR ARRANGEMENT OF LAMPSHADES IN FABRIC

DESIGN BRIAN RASMUSSEN, 2010

PRIVATE HOUSE _ BURANO / VENICE _ 2.10 PM





AQUA_ SO 12 CUSTOM
**COMPOSIZIONE MODULARE DI PARALUMI IN TESSUTO/
MODULAR ARRANGEMENT OF LAMPSHADES IN FABRIC**

DESIGN BRIAN RASMUSSEN, 2013



AQUA _ TA UP + MAXI TA UP
LAMPADA DA TAVOLO CON PARALUME IN TESSUTO /
TABLE LAMP WITH LAMPSHADES IN FABRIC

DESIGN BRIAN RASMUSSEN, 2013





AQUA_TR
**LAMPADA DA TERRA CON PARALUME IN TESSUTO/
FLOOR LAMP WITH LAMPSHADES IN FABRIC**

DESIGN BRIAN RASMUSSEN, 2013



AQUA TR
LAMPADA DA TERRA CON PARALUME IN TESSUTO/
FLOOR LAMP WITH LAMPSHADES IN FABRIC

DESIGN BRIAN RASMUSSEN, 2012





AQUA SPHERE 160 MIX 181
SOSPENSIONE MODULARE
DI PARALUMI IN TESSUTO/
MODULAR SUSPENDED LAMP
OF LAMPSHADES IN FABRIC

DESIGN BRIAN RASMUSSEN, 2012





AQUA _ SPHERE 160 MIX 18L
SOSPENSIONE MODULARE
DI PARALUMI IN TESSUTO /
MODULAR SUSPENDED LAMP
OF LAMPSHADES IN FABRIC

DESIGN BRIAN RASMUSSEN, 2012



AQUA SPHERE 80 18L
**SOSPENSIONE MODULARE DI PARALUMI IN TESSUTO/
MODULAR SUSPENDED LAMP OF LAMPSHADES IN FABRIC**

DESIGN BRIAN RASMUSSEN, 2012





106

FAÇON DE VENISE AQUA

AQUA SPHERE 80 18L
SOSPENSIONE MODULARE DI PARALUMI IN PVC ORO /
MODULAR SUSPENDED LAMP OF LAMPSHADES GOLD PVC

DESIGN BRIAN RASMUSSEN, 2013



107



AQUA _ SPHERE 70 MIX 9L
SOSPENSIONE MODULARE DI PARALUMI IN TESSUTO/
MODULAR SUSPENDED LAMP OF LAMPSHADES IN FABRIC

DESIGN BRIAN RASMUSSEN, 2012



AQUA _AP
LAMPADA DA PARETE
CON PARALUMI IN TESSUTO /
WALL LAMP WITH LAMPSHADES IN FABRIC

DESIGN BRIAN RASMUSSEN, 2012



Sistema modulare composto da paralumi diffusori nei colori: rosso ciliegia, verde erba, bianco crema, blu mare, azzurro cielo, marrone terra, biancolatte, nero petrolio.
Montatura in metallo bianco.

Modular system comprising diffuser lampshades in the following colours: cherry red, grass green, cream white, ocean blue, sky blue, earth brown, milk white and petrol black.
Fixture in white metal.

- 60W E27 ●
- 20W E27 ●
- 30W E27 ●
- 100W E27 ●
- 15W E27 ●

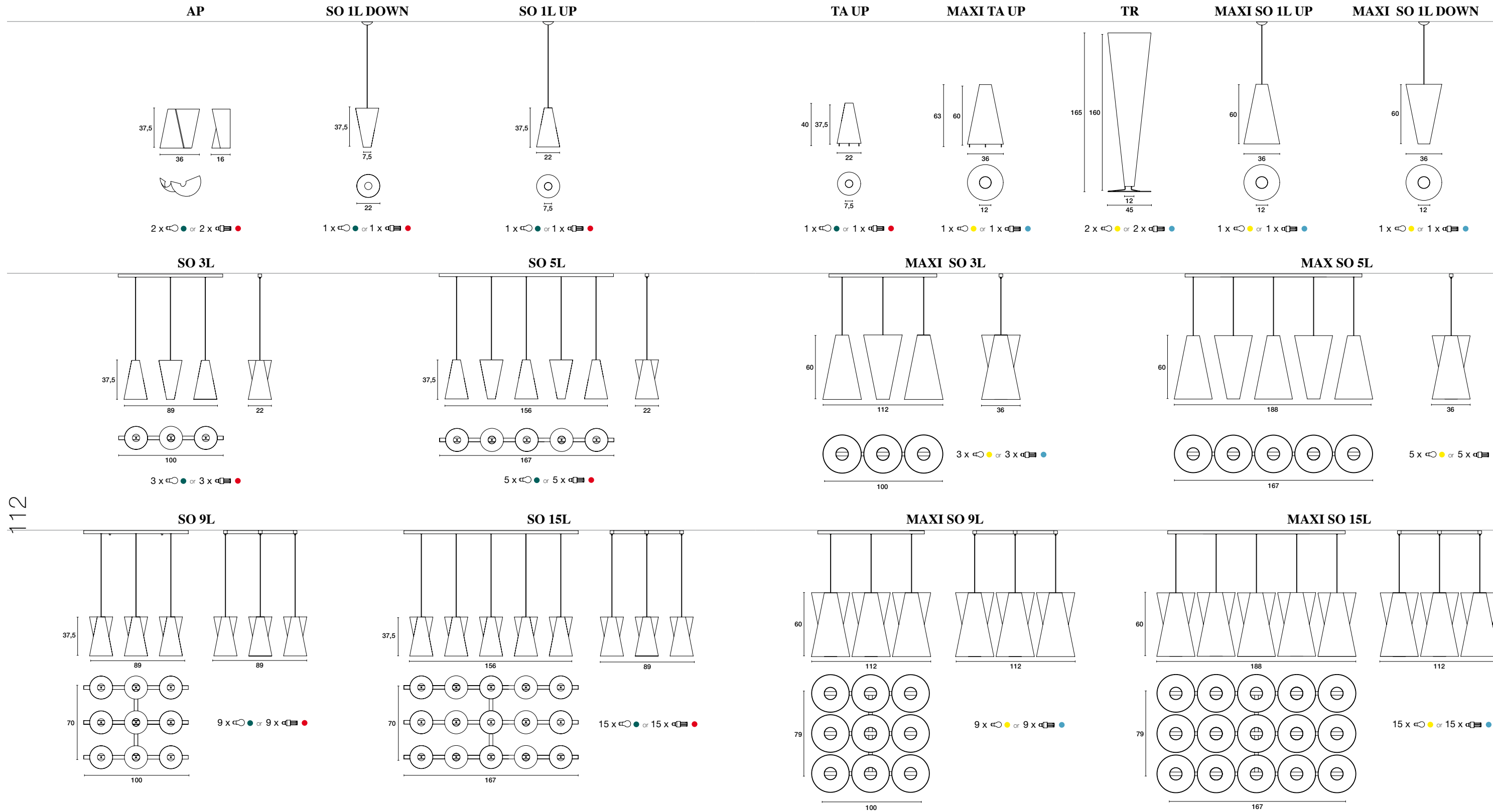

Sistema modulare composto da paralumi diffusori nei colori: rosso ciliegia, verde erba, bianco crema, blu mare, azzurro cielo, marrone terra, biancolatte, nero petrolio.
Montatura in metallo bianco.

Modular system comprising diffuser lampshades in the following colours: cherry red, grass green, cream white, ocean blue, sky blue, earth brown, milk white and petrol black.
Fixture in white metal.

- 60W E27
- 20W E27
- 30W E27
- 100W E27
- 15W E27

SPHERE 50 9L

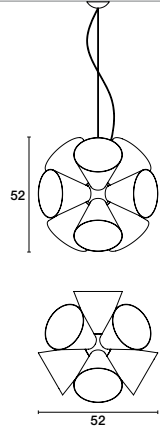

9 x ●

SPHERE 60 9L

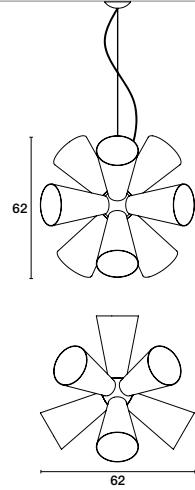

9 x ●

SPHERE 70 9L

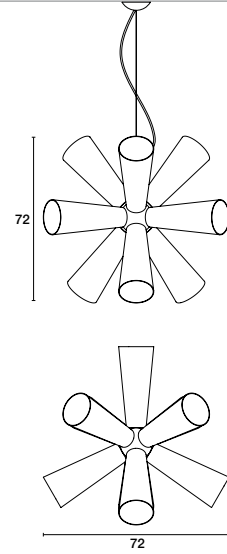

9 x ●

SPHERE 70 mix 9L

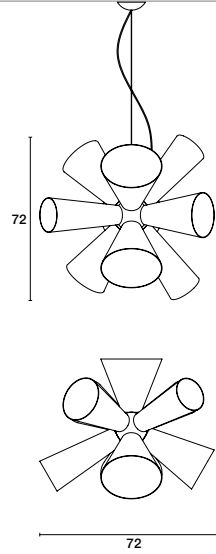

9 x ●

SPHERE 60 18L

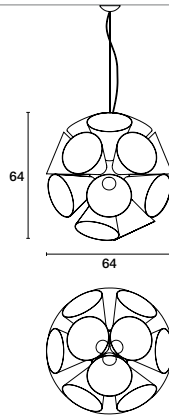

18 x ●

SPHERE 80 18L

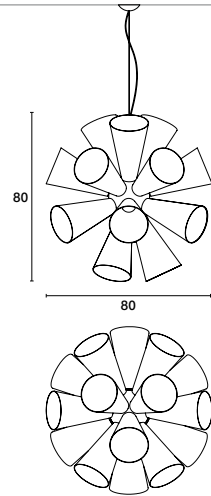

18 x ●

SPHERE 100 18L

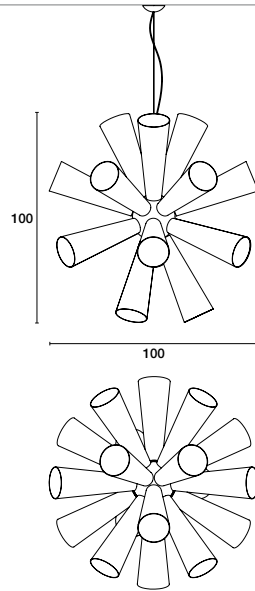

18 x ●

SPHERE 100 mix 18L

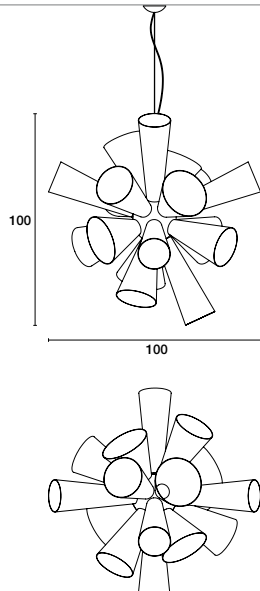

18 x ●

SPHERE 120 18L

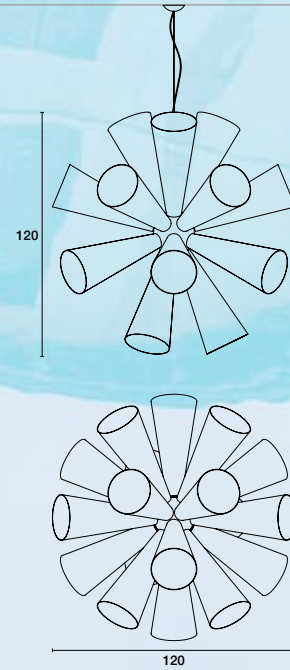

18 x ●

SPHERE 160 18L

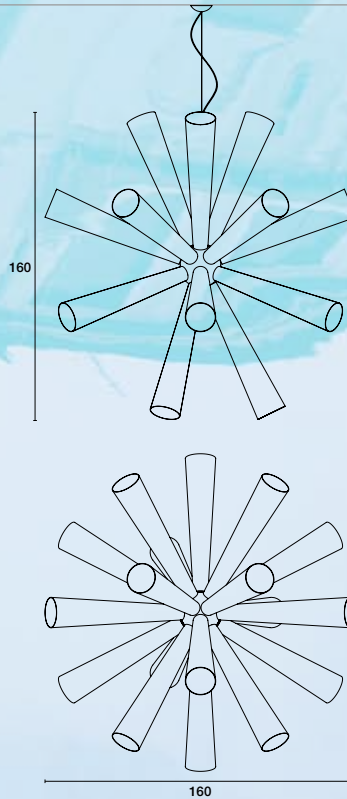

18 x ●

SPHERE 160 mix 18L

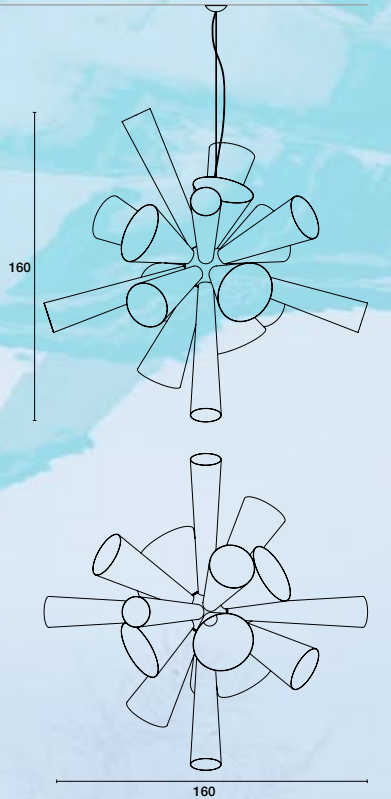

18 x ●



LIMELIGHT

design lorenzo bertocco

LIMELIGHT_28.6
**LAMPADARIO DESTRUTTURATO IN CRISTALLO/
DECONSTRUCTED CHANDELIER IN CRYSTAL GLASS**

DESIGN LORENZO BERTOCCO, 1999



LIMELIGHT_28.6
**LAMPADARIO DESTRUTTURATO IN CRISTALLO/
DECONSTRUCTED CHANDELIER IN CRYSTAL GLASS**

DESIGN LORENZO BERTOCCO, 1999





LIMELIGHT_12.4
**LAMPADARIO DESTRUTTURATO IN CRISTALLO/
DECONSTRUCTED CHANDELIER IN CRYSTAL GLASS**

DESIGN LORENZO BERTOCCO, 1999





LIMELIGHT_11
FARETTO CON ELEMENTI IN CRISTALLO/
SPOTLIGHT WITH ELEMENTS IN CRYSTAL GLASS

DESIGN LORENZO BERTOCCO, 1999









Thanks to its modular nature, complex installations can be created with the Limelight collection; true architectural lighting with great visual appeal.

SECTIONAL & MODULAR COMPONIBILE & MODULARE

La collezione Limelight, in quanto modulare, permette la realizzazione di installazioni complesse, vere e proprie architetture di luce dal grande impatto visivo.

LIMELIGHT
COMPOSIZIONE DESTRUTTURATO IN CRISTALLO /
DECONSTRUCTED COMPOSITION IN CRYSTAL GLASS

DESIGN LORENZO BERTOCCO, 2012







LIMELIGHT
design lorenzo bertocco

Diffusore in vetro cristallo
trasparente, nero e trasparente
o bianco e trasparente.
Montatura in inox lucido.

Diffuser in transparent,
black/transparent or white/transparent
crystal glass.
Fixture in polished stainless steel.

50 W GU10  ●
50 W G53 QR111  ●

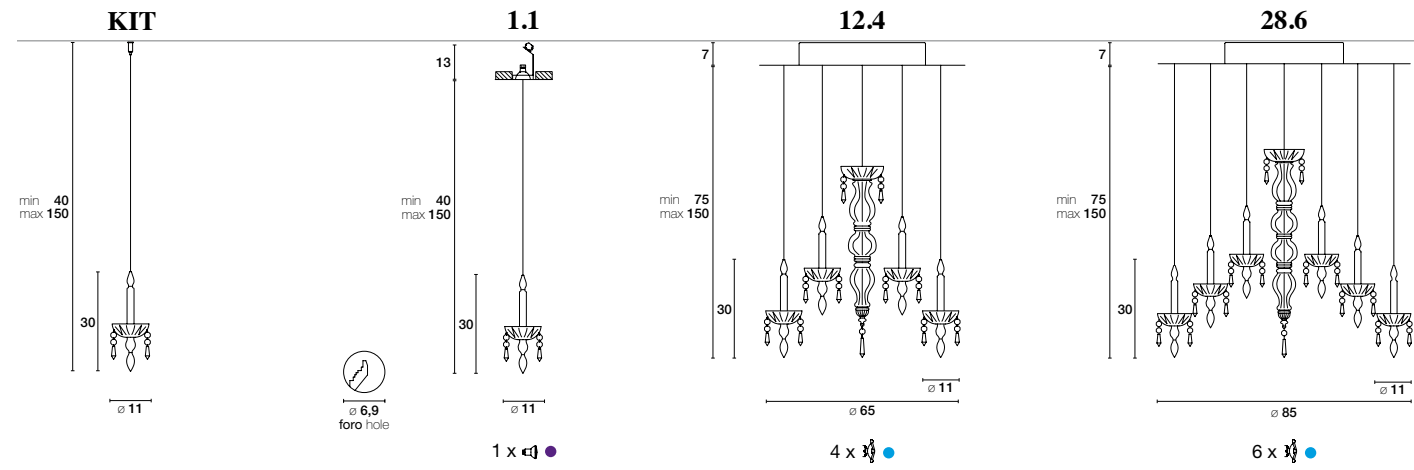

LIMELIGHT
table of contents



TRADITIONS AND CONTEMPORARY STYLE

Natural elements and man's creations have always existed in Venice:
an ideal place for designing and making original lighting elements.
But everyday reality requires research.
Façon de Venise contaminates Venetian traditions, discovers new paths and looks beyond the horizon,
with a desire to excite and seize the style of our times.

STORIE E
CONTEMPORANEO

STORIE E
CONTEMPORANEO

A Venezia da sempre si incontrano elementi della natura e idee dell'uomo:
un luogo ideale per disegnare e costruire forme di luce originali.
Ma la realtà odierna ci impone la ricerca.
Façon de Venise contamina memorie veneziane, scopre nuove vie
e volge lo sguardo oltre l'orizzonte,
con il desiderio di emozionare e catturare il gusto del nostro tempo.



DRILL

design cambi scatena turini

**DRILL AP/PL 80,
PLAFONIERA IN GESSO DECORATO/
CEILING LAMP IN ORNAMENTED PLASTER**

DESIGN CAMBI SCATENA TURINI, 2013



**DRILL AP/PL 40,
APPLIQUE IN GESSO DECORATO/
WALL LAMP IN ORNAMENTED PLASTER**

DESIGN CAMBI SCATENA TURINI, 2013



**DRILL _ SO 80,
SOSPENSIONE IN GESSO DECORATO/
SUSPENDED LAMP IN ORNAMENTED PLASTER**

DESIGN CAMBI SCATENA TURINI, 2013





**DRILL_ SO 80,
SOSPENSIONE IN GESSO DECORATO/
SUSPENDED LAMP IN ORNAMENTED PLASTER**

DESIGN CAMBI SCATENA TURINI, 2013

Lampada in gesso decorato.
Lamp in ornamented plaster.

- 60W G9
- 55W 2GX13
- 17.5W LED 220-240V 3000°K
- 13W LED 220-240V 3000°K

AP/PL 40

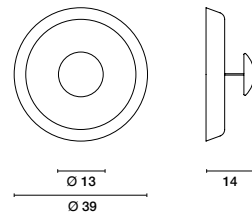

1 x or 1 x LED

AP/PL 80

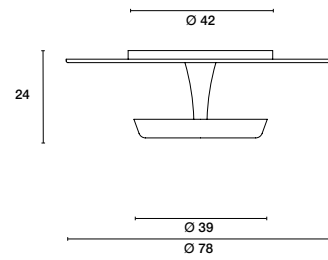

1 x or 3 x LED

KIT SO 80 PLUS

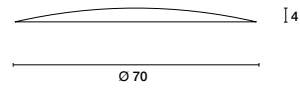

diffusore metacrilato monosatinato
diffuser in satinated methacrylate

SO 80

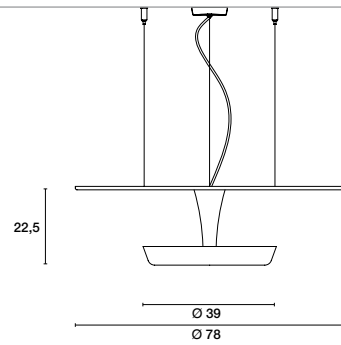

1 x or 3 x LED

SO 80 PLUS

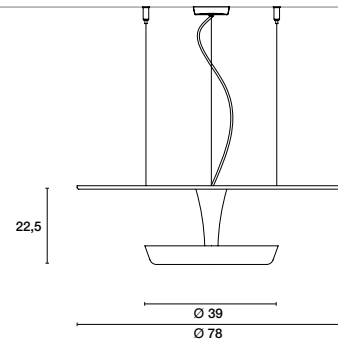

1 x or 3 x LED + 2 x LED



DRILL
table of contents



design lorenzo bertocco
MALIVIZI

MALIVIZI _SO 50
**SOSPENSIONE IN LEGNO CURVATO/
SUSPENDED LAMP IN CURVED WOOD**

DESIGN LORENZO BERTOCCO, 2007



MALIVIZI _SO 60
**SOSPENSIONE IN LEGNO CURVATO/
SUSPENDED LAMP IN CURVED WOOD**



DESIGN LORENZO BERTOCCO, 2007









Diffusore in legno con fasce alternate
di faggio, pero e bolivar.
Montatura in metallo bianco.

Diffuser in wood with alternating strips
in beech, pear wood and bolivar wood.
Fixture in white metal.

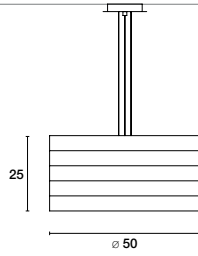
250W E27  ●
150W E27  ●
23W E27  ●



SO50

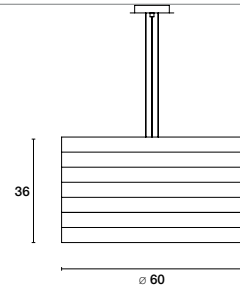

1 x  ● or 1 x  ● or 1 x  ●

SO60



1 x  ● or 1 x  ● or 1 x  ●

MALIVIZI
table of contents



CHANDELIER

design peter lunetta

MERIPRS
SUZANNE
EMY
REBECCA
MAMO
BARBARA
NICOLE
MARIANGE
VANESSA
CHRISTINE



**MERIPIRS,
LAMPADARIO IN GOMMA SPECIALE COLORATA/
LAMP IN SPECIAL COLOURED RUBBER**

DESIGN PETER LUNETTA, 2005

**MERIPIRS,
LAMPADARIO IN GOMMA SPECIALE COLORATA/
LAMP IN SPECIAL COLOURED RUBBER**

DESIGN PETER LUNETTA, 2005

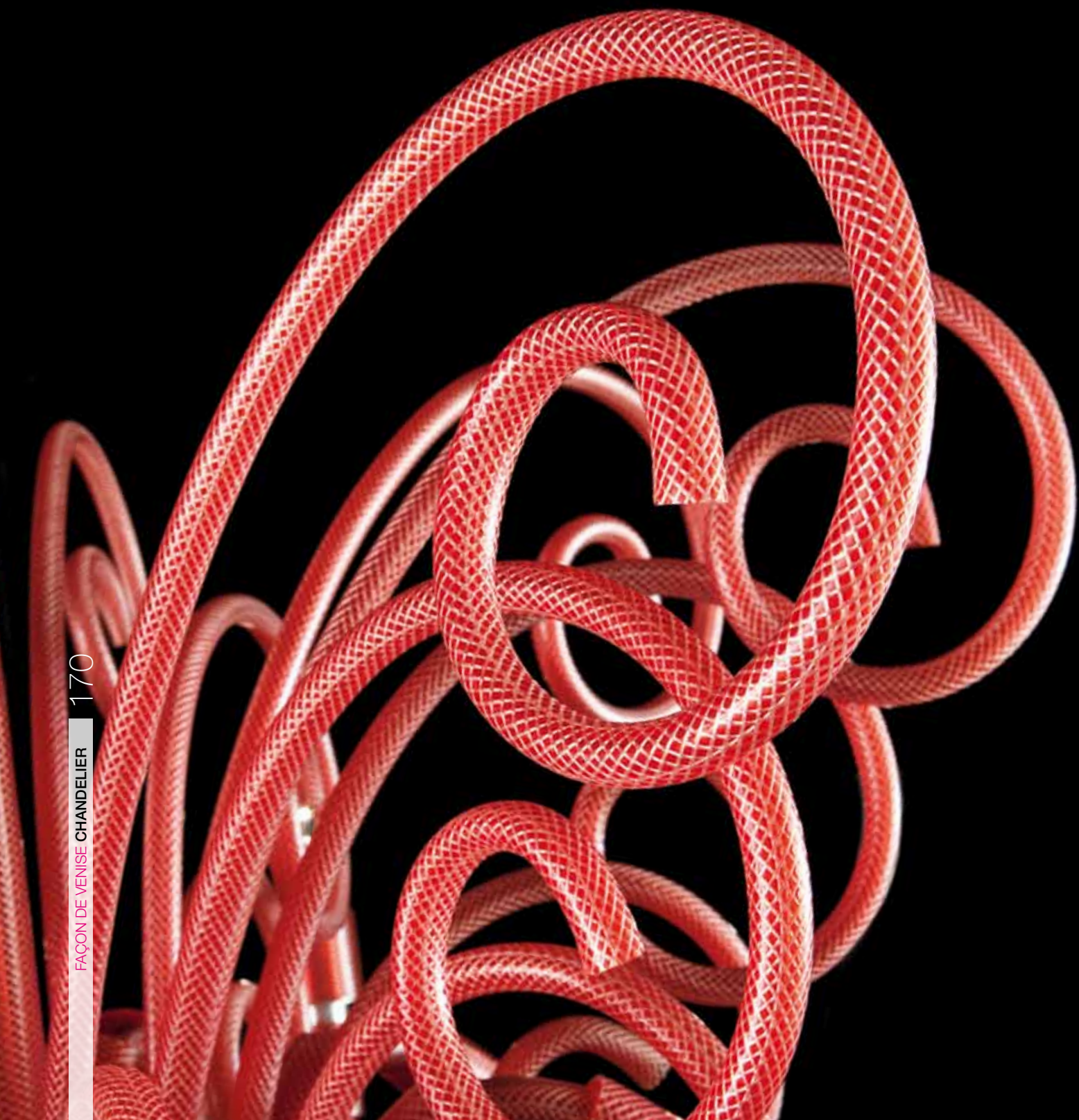

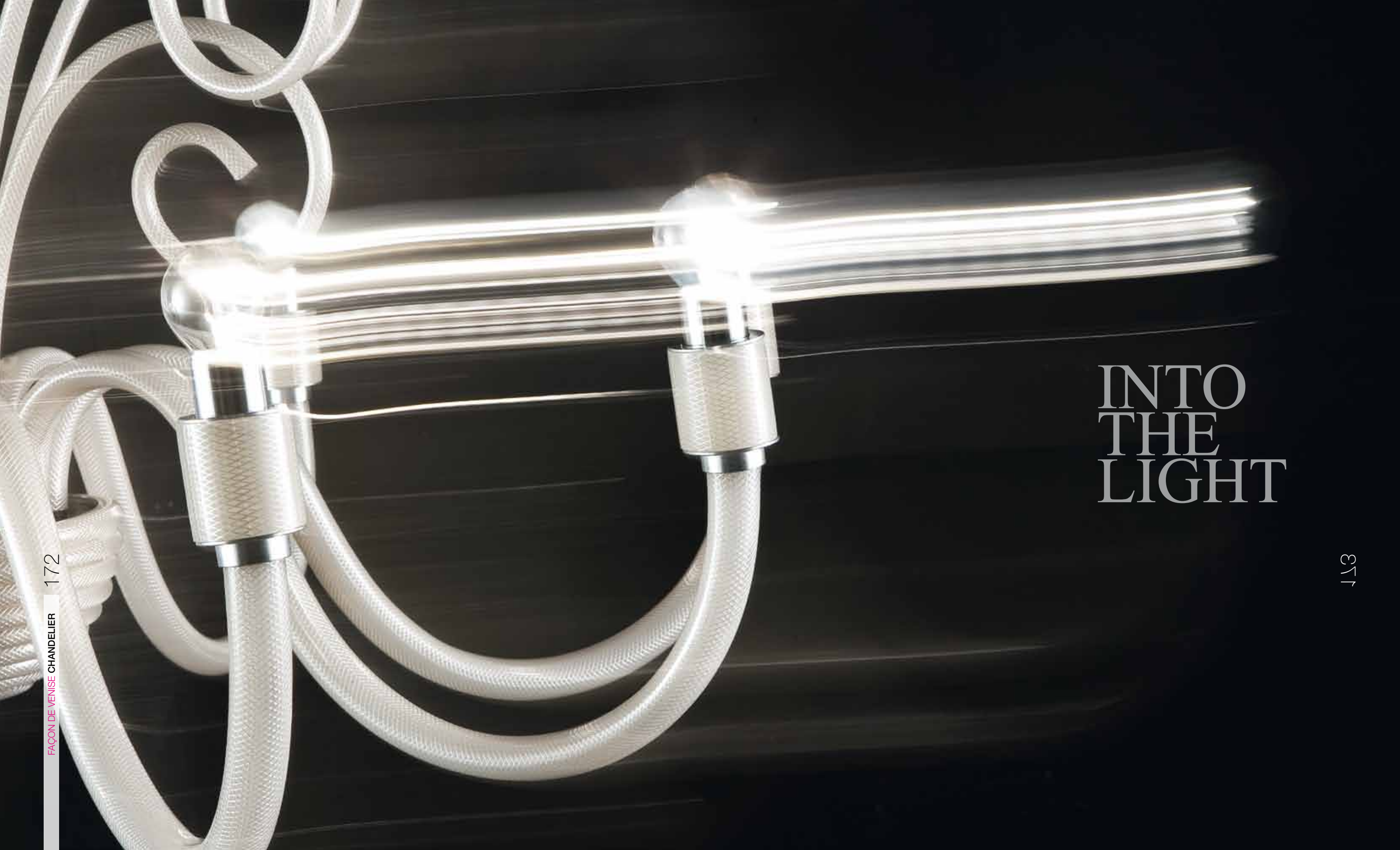

INTO THE LIGHT

**SUZANNE,
LAMPADARIO IN GOMMA SPECIALE COLORATA/
LAMP IN SPECIAL COLOURED RUBBER**

DESIGN PETER LUNETTA, 2005



**SUZANNE,
LAMPADARIO IN GOMMA SPECIALE COLORATA/
LAMP IN SPECIAL COLOURED RUBBER**

DESIGN PETER LUNETTA, 2005



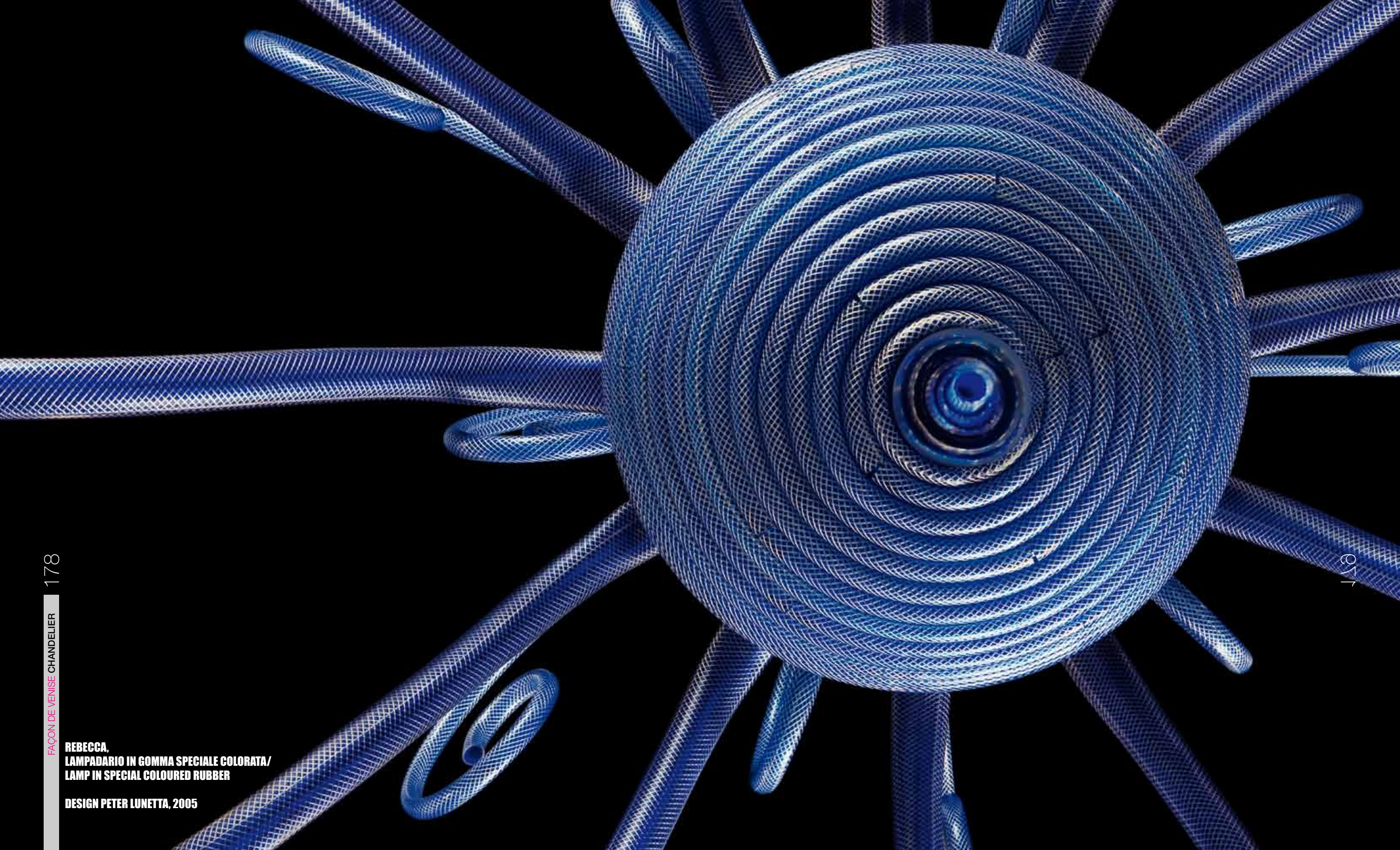

**REBECCA,
LAMPADARIO IN GOMMA SPECIALE COLORATA/
LAMP IN SPECIAL COLOURED RUBBER**

DESIGN PETER LUNETTA, 2005



BARBARA,
LAMPADARIO IN GOMMA SPECIALE COLORATA/
LAMP IN SPECIAL COLOURED RUBBER

DESIGN PETER LUNETTA, 2005



**BARBARA,
LAMPADARIO IN GOMMA SPECIALE COLORATA/
LAMP IN SPECIAL COLOURED RUBBER**

DESIGN PETER LUNETTA, 2005



"CAFFÈ FLORIAN" _ S. MARCO SQUARE / VENICE _ 11.00 AM

**CHRISTINE,
APPLIQUE IN GOMMA SPECIALE COLORATA/
WALL LAMP IN SPECIAL COLOURED RUBBER**

DESIGN PETER LUNETTA, 2005









CHANDELIER

design peter lunetta

Lampadario in gomma nei colori:
bianco, ambra, nero, rosso fuoco, fuxia,
blu, verde acido.
Montatura in metallo bianco.

Rubber lamp in the following colours:
white, amber, black, flame red, fuchsia,
blue and acid green.
Fixture in white metal.

60W E14  
11W E14  



CHANDELIER

table of contents

IP

IP 44

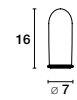

CHRISTINE 2P

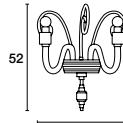

40 SP 30

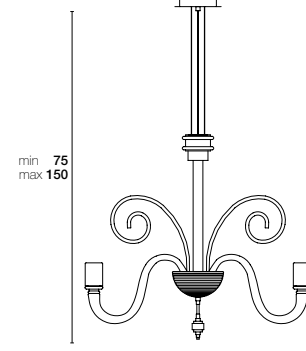

2 x  or 2 x 

REBECCA 12L



min 75
max 150

ø 110

12 x  or 12 x 

MERIPIRS 8L

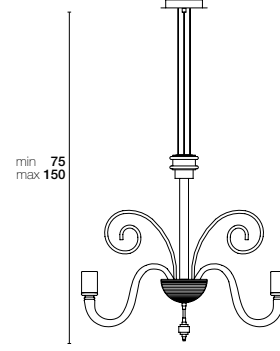

min 75
max 150

ø 100

8 x  or 8 x 

EMY 8L

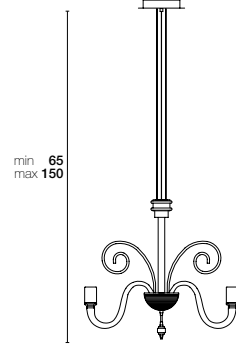

min 65
max 150

ø 75

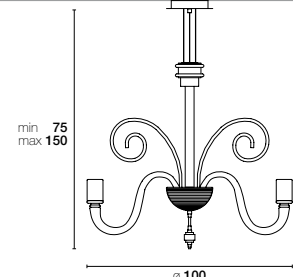

8 x  or 8 x 

SUZANNE 8L



min 75
max 150

ø 100

8 x  or 8 x 

BARBARA 6L

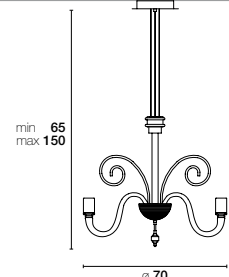

min 65
max 150

ø 70

6 x  or 6 x 

NICOLE 3L

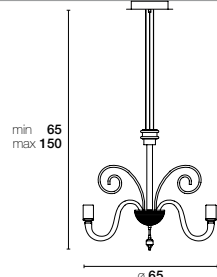

min 65
max 150

ø 65

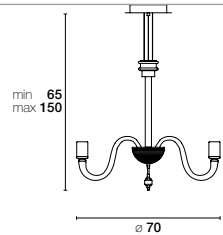

3 x  or 3 x 

MARIANGE 8L



min 65
max 150

ø 70

8 x  or 8 x 

VANESSA 6L

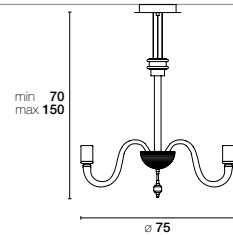

min 70
max 150

ø 75

6 x  or 6 x 

MAMO 6L

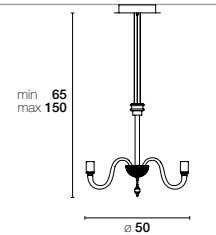

min 65
max 150

ø 50

3 x  or 3 x 

MAMO 3L

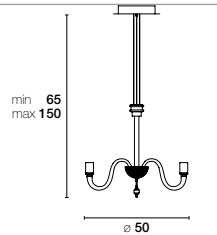

min 65
max 150

ø 50

3 x  or 3 x 

BRICK

design brian rasmussen

**BRICK COMPO 2 SQ 60,
COMPOSIZIONE MODULARE IN TESSUTO /
MODULAR COMPOSITION IN FABRIC**

DESIGN BRIAN RASMUSSEN, 2013







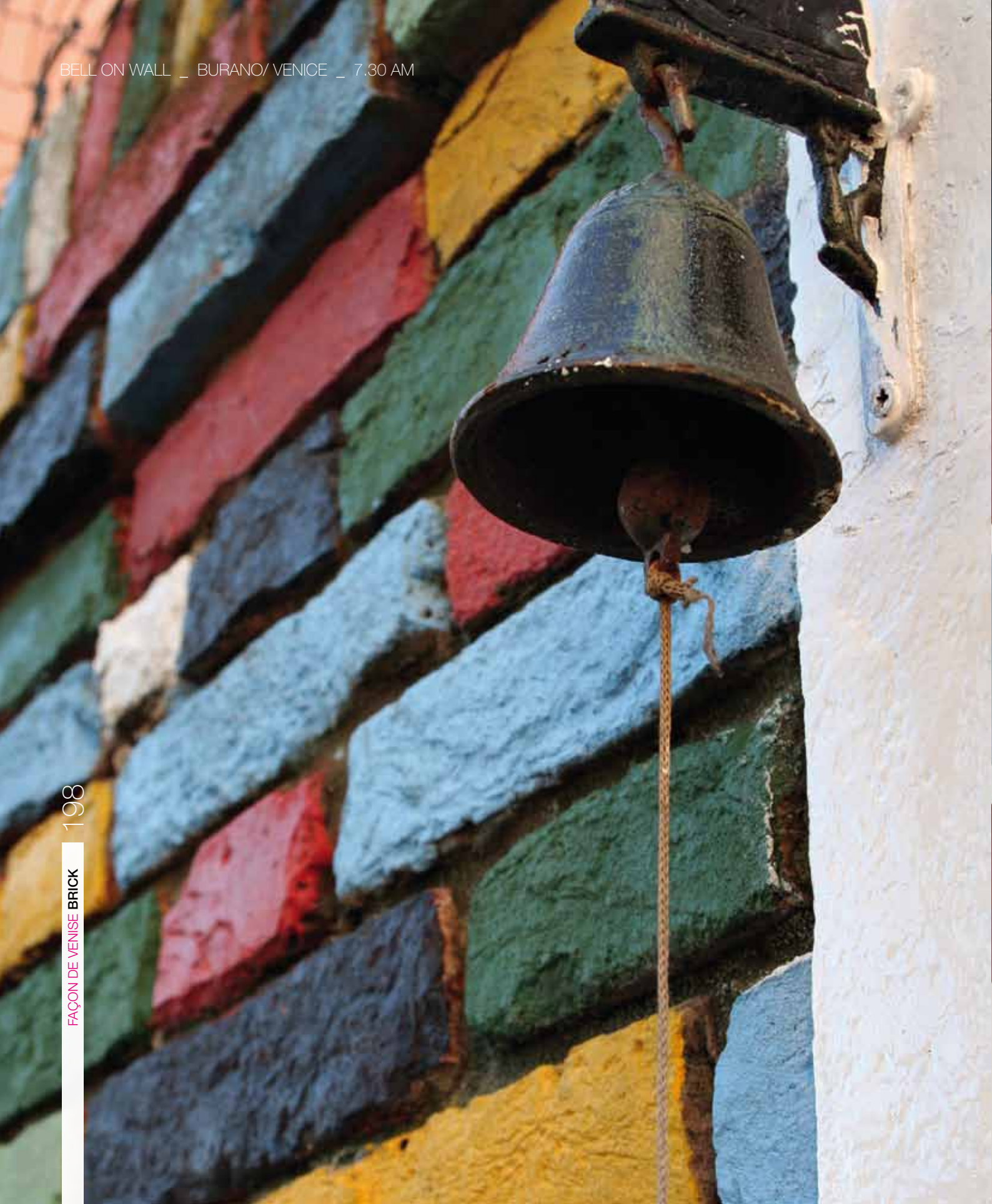

**BRICK COMPO MAXI,
COMPOSIZIONE SPECIALE IN TESSUTO/
SPECIAL COMPOSITION IN FABRIC**

DESIGN BRIAN RASMUSSEN, 2013





**BRICK _ AP/PL SQ 60,
SEQUENZA DI MONTAGGIO/
ASSEMBLY SEQUENCE**

DESIGN BRIAN RASMUSSEN, 2013

Brick in the Wall



**BRICK _ COMPO 4 AP/PL 75,
COMPOSIZIONE MODULARE IN TESSUTO/
MODULAR COMPOSITION IN FABRIC**

DESIGN BRIAN RASMUSSEN, 2013

**BRICK _ COMPO 2 AP/PL 75,
COMPOSIZIONE MODULARE IN TESSUTO/
MODULAR COMPOSITION IN FABRIC**

DESIGN BRIAN RASMUSSEN, 2013





208

FAÇON DE VENISE BRICK

**BRICK _ 2 AP/PL 150,
COMPOSIZIONE MODULARE IN TESSUTO/
MODULAR COMPOSITION IN FABRIC**

DESIGN BRIAN RASMUSSEN, 2013



209

**BRICK _ 2 AP/PL 45,
COMPOSIZIONE MODULARE IN TESSUTO/
MODULAR COMPOSITION IN FABRIC**

DESIGN BRIAN RASMUSSEN, 2013

BRICK AP/PL SQ 60.
COMPOSIZIONE MODULARE IN PVC ORO /
MODULAR COMPOSITION IN GOLD PVC

DESIGN BRIAN RASMUSSEN, 2013



Lampada modulare. Montatura metallo verniciato bianco. Diffusore in metacrilato bianco con elementi decorativi in tessuto vari colori.

Modular lamp. White painted metal frame. Diffuser in white methacrylate with decorative elements in fabric several colors.

- 22W 2GX13 ●
- 24W G5 ●
- 55W 2GX13 ●
- 39W G5 ●

AP/PL 45

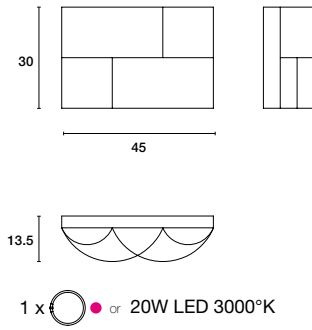

AP/PL 75

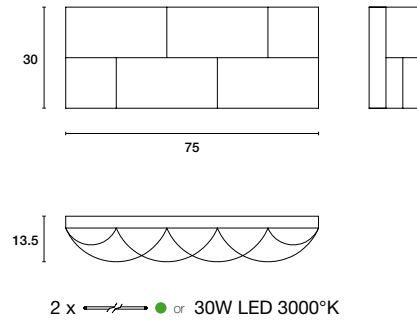

AP/PL SQ 45

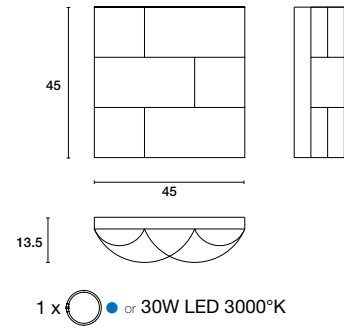

AP/PL SQ 60

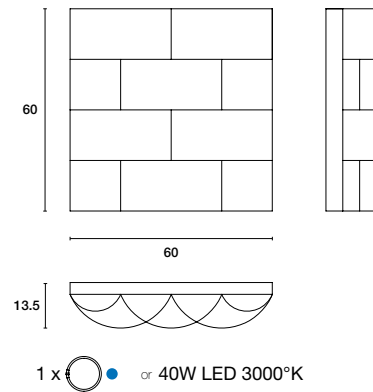

AP/PL 150

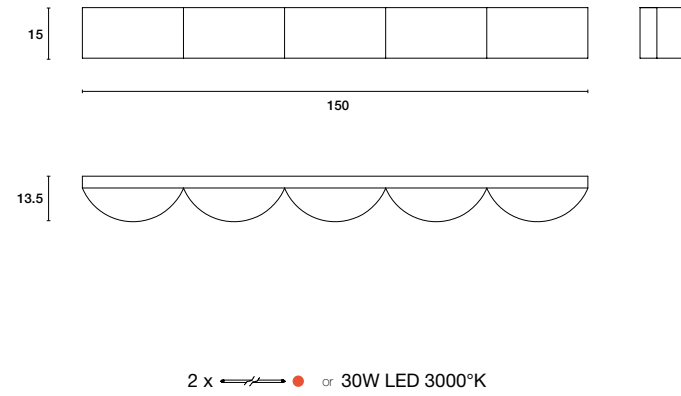

COMPO 4 AP/PL 75

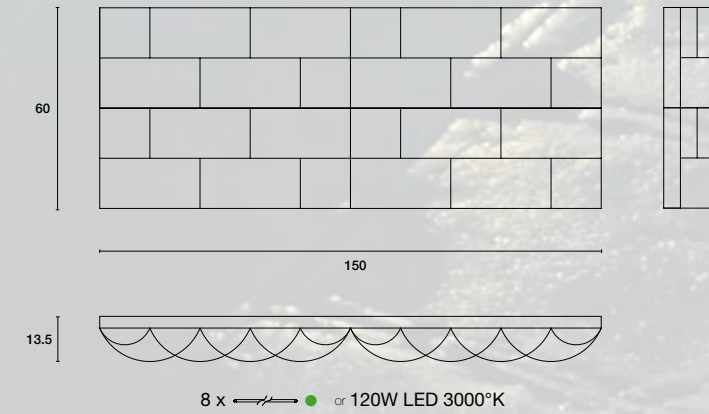

COMPO 2 AP/PL SQ 60

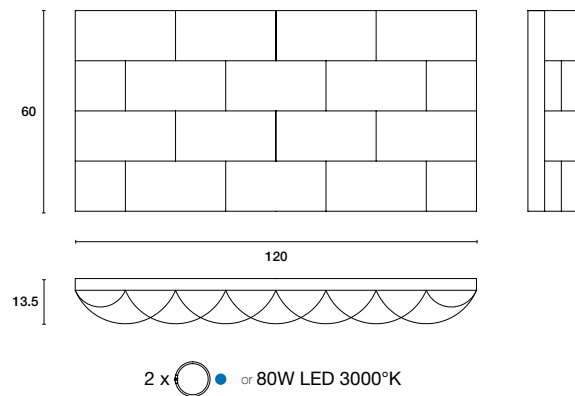

COMPO 2 AP/PL 75

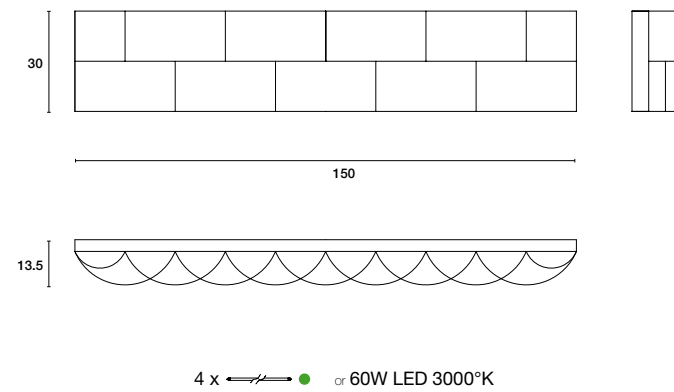

COMPO MAXI

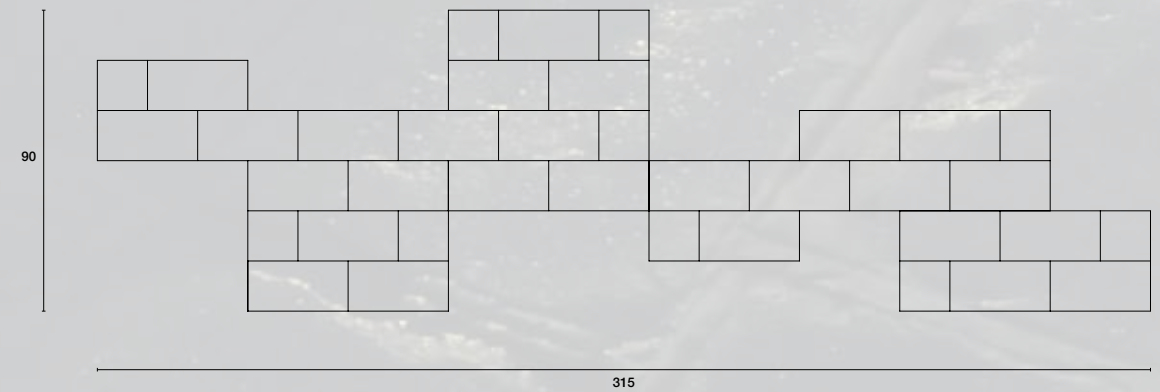

DISH design andrea lazzari



DISH
LAMPADA A SPECCHIO RGB/
RGB MIRROR LAMP

DESIGN ANDREA LAZZARI, 2010

DISH
LAMPADA A SPECCHIO RGB/
RGB MIRROR LAMP

DESIGN ANDREA LAZZARI, 2010



DISH
**LAMPADA A SPECCHIO/
MIRROR LAMP**

DESIGN ANDREA LAZZARI, 2010

"CENTRALE" LOUNGE BAR _ S. MARCO / VENICE _ 3.05 PM







" PONTE DEI FRARI " _ VENICE _ 6.45 PM



DISH_PL
PLAFONIERA IN METACRILATO TERMOCURVATO/
CEILING LAMP IN HEAT-BENT METHACRYLATE

DESIGN ANDREA LAZZARI, 2010

DISH
design andrea lazzari

Diffusore in metacrilato bianco lucido
o bianco lucido con specchio.
Montatura in metallo bianco, particolari in cromo.

Diffuser in gloss white methacrylate
or white with mirror finish.
Fixture in white metal
with chrome-plated details.

55W 2GX13
15W E27



TELECOMANDO RGB
RGB REMOTE CONTROL

DISH
table of contents

MI 60

AP/PL 60

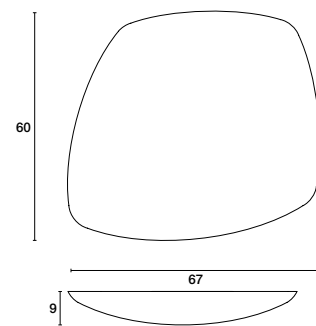
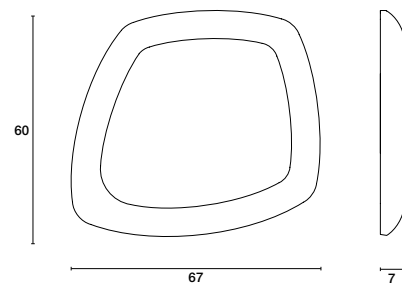

1 x ●
or 1 x ● + RGB LED STRIP 7W + REMOTE CONTROL
or RGB LED STRIP 7W + REMOTE CONTROL

3 x ● or 1 x ●



FV design viale 34

FV_60
**PLAFONIERA DA INCASSO/
BUILT-IN CEILING LAMP**

DESIGN VIALE 34, 2009



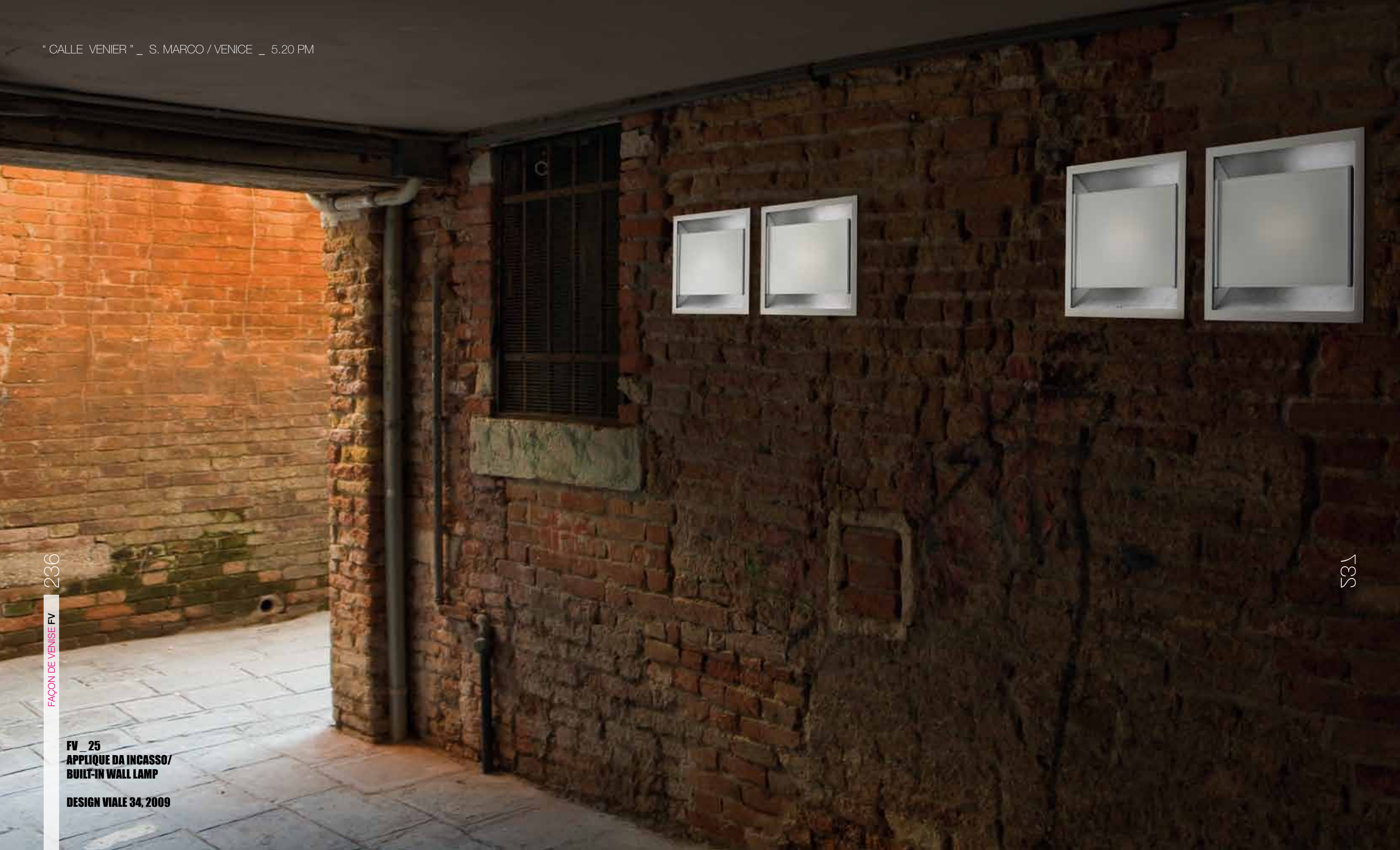

FV_25
**APPLIQUE DA INCASSO/
BUILT-IN WALL LAMP**
DESIGN VIALE 34, 2009



FV_40
**APPLIQUE DA INCASSO/
BUILT-IN WALL LAMP**





DESIGN VIALE 34, 2009



FV_10
**FARI DA INCASSO/
BUILT-IN SPOTLIGHTS**
DESIGN VIALE 34, 2009



Lampada ad incasso da parete e soffitto. Built-in wall and ceiling lamp.
 Montatura metallo bianco opaco, Fixture in matt white metal,
 nero opaco, inox lucido. matt black or polished stainless steel.
 Parabola bianca, gialla, foglia oro, foglia argento. Parabolic louver in white, yellow,
 Diffusore in vetro piano o curvo gold leaf or silver leaf.
 nei colori nero lucido, Diffuser in flat or curved glass
 bianco lucido o specchio in the following colours:
 gloss black, gloss white or mirror finish.

- 35W GU 4 
- 150W R7s 114 mm 
- 24W 2G10 
- 55W 2G11 
- 50W GU10 

FV10/90°

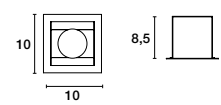

1 x 

FV10/45°

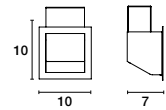

1 x 

FV25

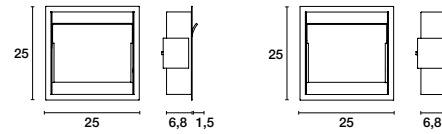

1 x  or 1 x 

FV40

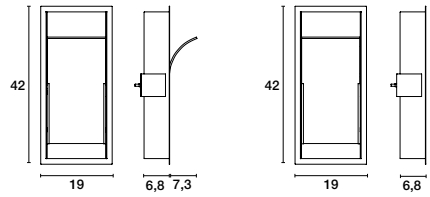

1 x  or 1 x 

FV60

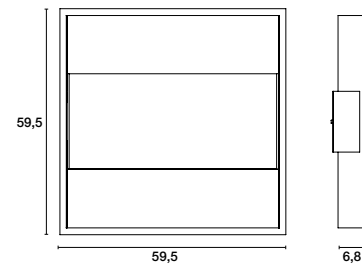

1 x 

**OUTER CASING
FV10/45°**

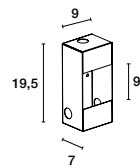

**OUTER CASING
FV10/90°**

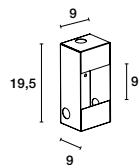

**OUTER CASING
FV25**

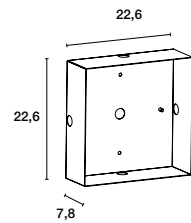

**OUTER CASING
FV40**

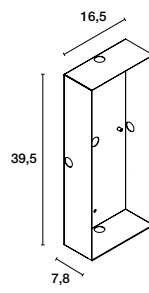

**OUTER CASING
FV60**

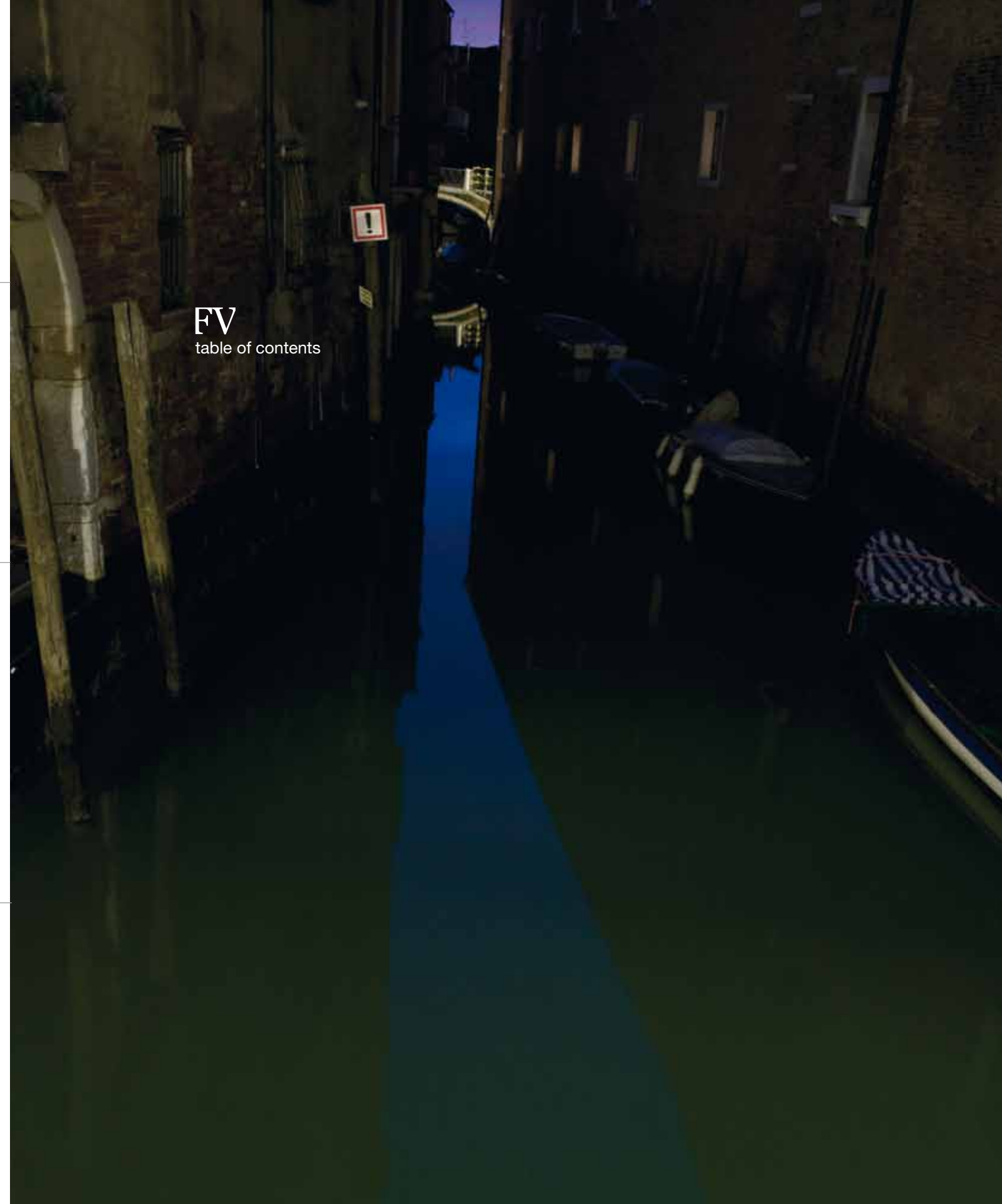
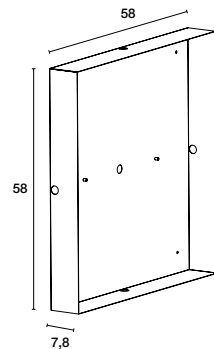

FV
table of contents



NOT ONLY DESIGN

Venice is inspiration, colours and tradition.
Façon de Venise is modern, original and exuberant:
new sources of light are inspired by the bustling places of a timeless city.

E NON SOLO
DESIGN

DESIGN
E NON SOLO

Venezia è ispirazione, colori e storia.
Façon de Venise è giovane, originale, esuberante:
nuove esperienze di luce nascono dall'incontro con i luoghi più vivi
di una città senza tempo.

250

CLAUDE

design lorenzo bertocco

251



CLAUDE _ S
**TUBI LUMINOSI IN PIREX/
LUMINOUS TUBES IN PYREX**

DESIGN LORENZO BERTOCCO, 2009



CLAUDE S
TUBI LUMINOSI IN PIREX/
LUMINOUS TUBES IN PYREX

DESIGN LORENZO BERTOCCO, 2009





CLAUDE _ AP
**TUBI LUMINOSI IN PIREX/
LUMINOUS TUBES IN PYREX**
DESIGN LORENZO BERTOCCO, 2009

CLAUDE _ S
**TUBI LUMINOSI IN PIREX/
LUMINOUS TUBES IN PYREX**
DESIGN LORENZO BERTOCCO, 2009

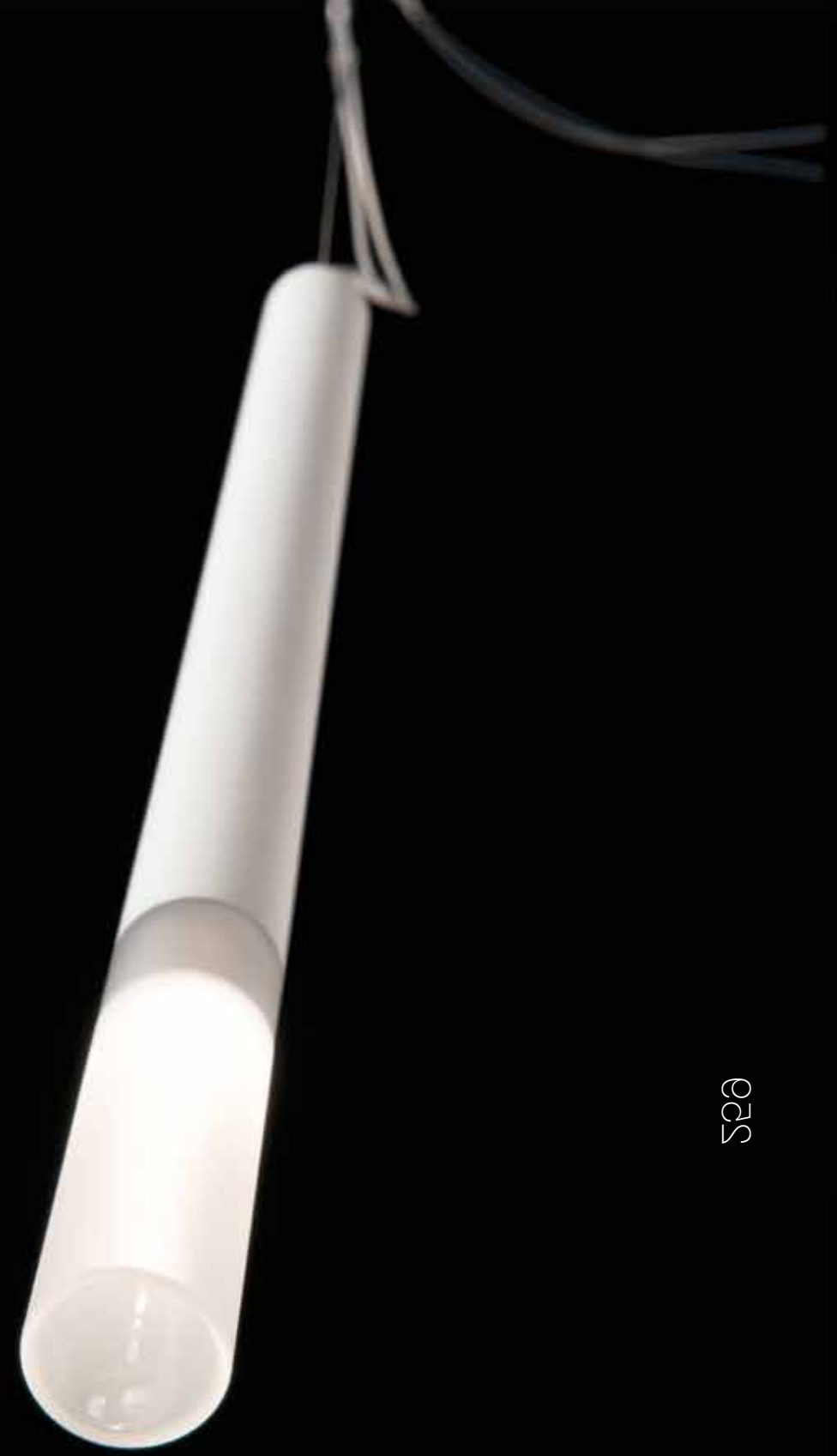

CLAUDE _ S
**TUBI LUMINOSI IN PIREX/
LUMINOUS TUBES IN PYREX**

DESIGN LORENZO BERTOCCO, 2009





Diffusore in vetro nei colori: bianco gesso con terminale cristallo satinato o nero grafite con terminale cristallo satinato. Montatura in metallo cromo.
Glass diffuser in the following colours: chalky white with end element in satin crystal glass, or graphite black with end element in satin crystal glass. Fixture in chrome-plated metal.

35W GY 6.35 12V 

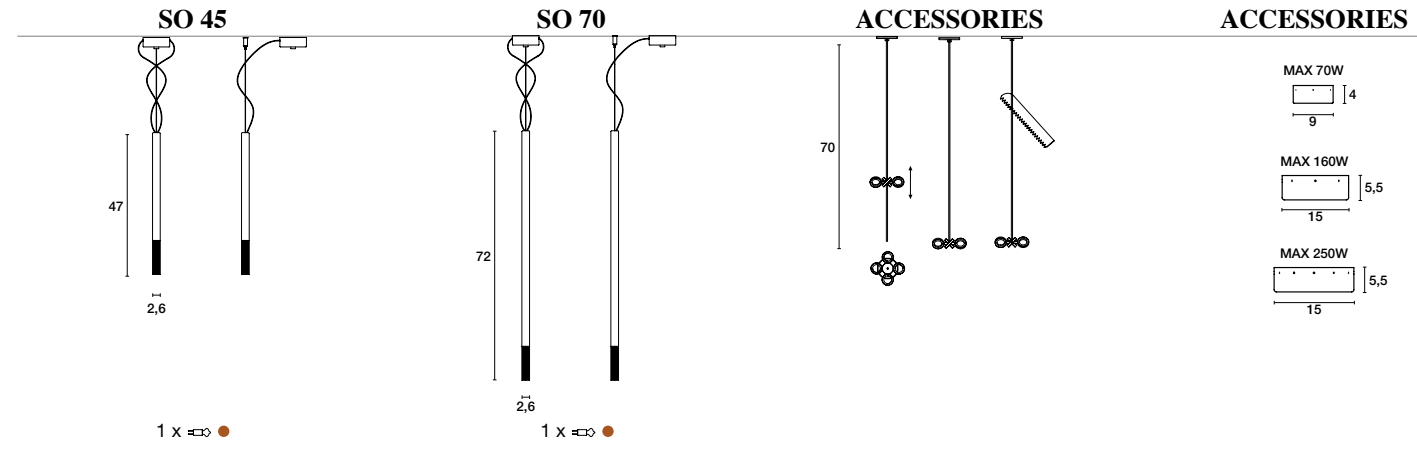

COMPOSITION 1

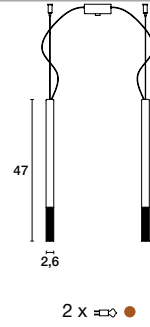

COMPOSITION 2

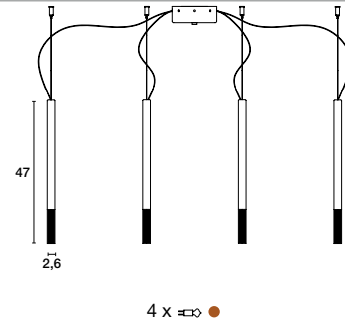

COMPOSITION 3

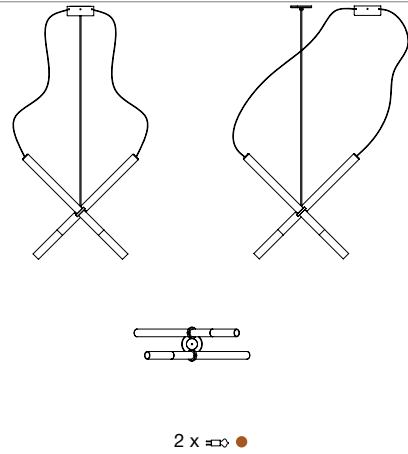

COMPOSITION 4

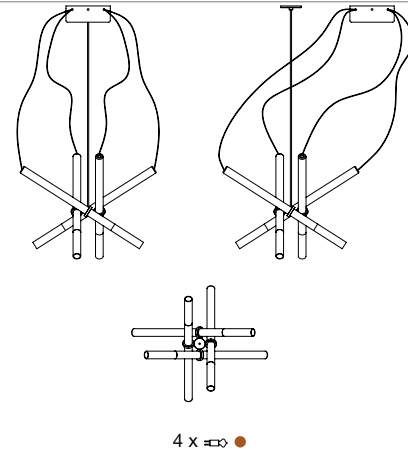

CLAUDE
table of contents



BLOOM

design brian rasmussen



**BLOOM _ SO 120,
SOSPENSIONE IN METALLO TORNITO E CURVATO/
SUSPENDED LAMP IN CURVED LATHE-TURNED METAL**

DESIGN BRIAN RASMUSSEN, 2009

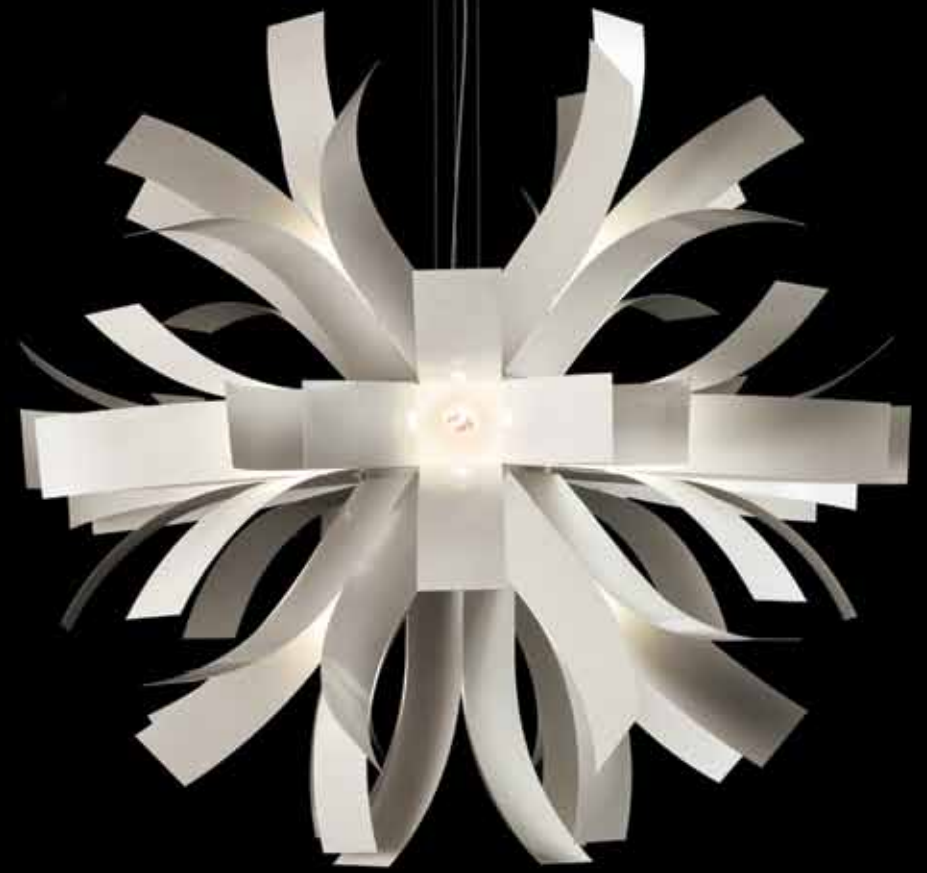

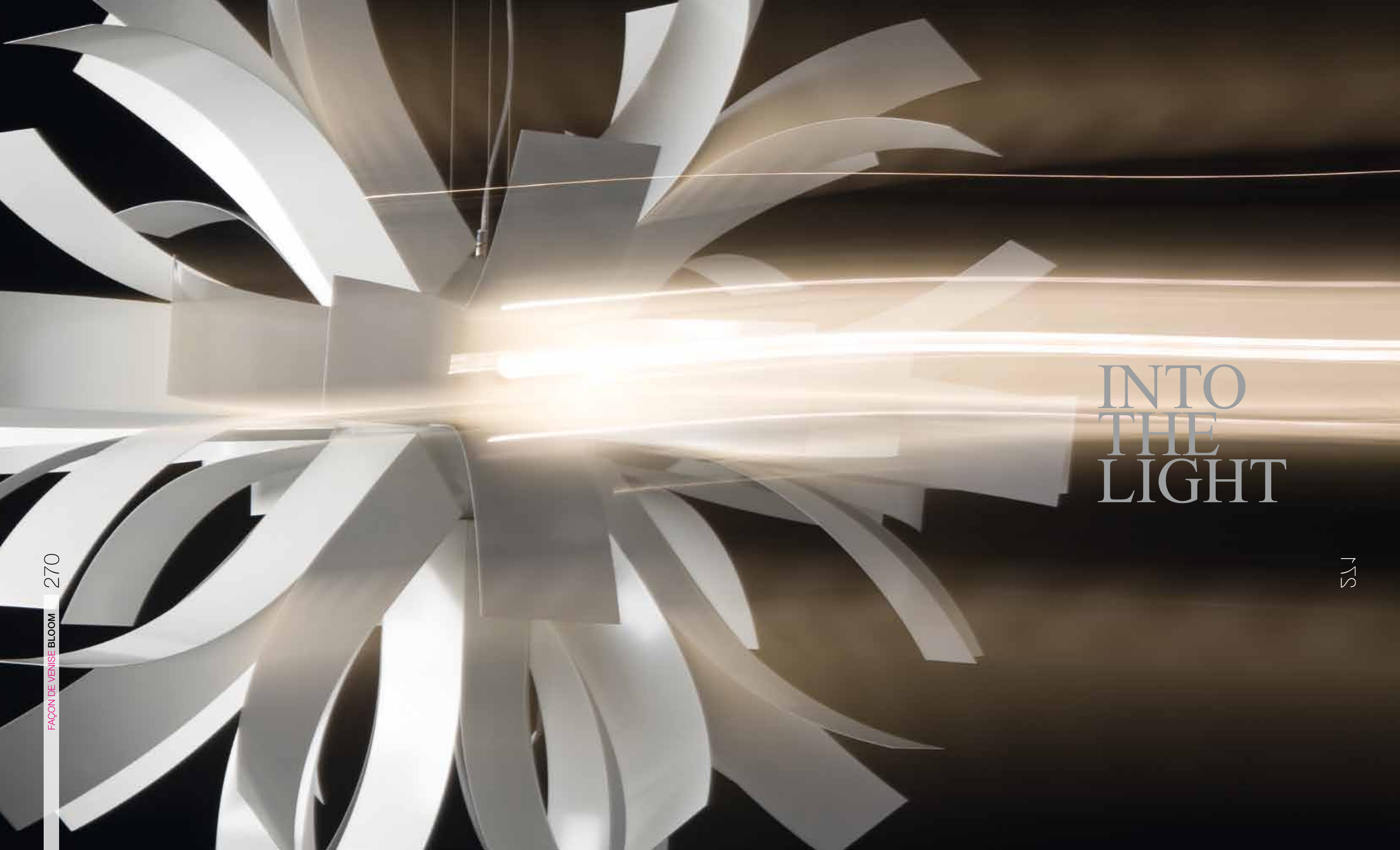

INTO THE LIGHT

**BLOOM SO 120,
SOSPENSIONE IN METALLO TORNITO E CURVATO/
SUSPENDED LAMP IN CURVED LATHE-TURNED METAL**

DESIGN BRIAN RASMUSSEN, 2009



**BLOOM _ PL 120,
PLAFONIERA IN METALLO TORNITO E CURVATO/
CEILING LAMP IN CURVED LATHE-TURNED METAL**

DESIGN BRIAN RASMUSSEN, 2009







**BLOOM _ SO 80,
SOSPENSIONE IN METALLO TORNITO E CURVATO/
SUSPENDED LAMP IN CURVED LATHE-TURNED METAL**

DESIGN BRIAN RASMUSSEN, 2009

Diffusore in metallo bianco o bianco / foglia oro.
Montatura in metallo bianco o foglia oro.

Diffuser in white metal or white / gold leaf.
Fixture in white metal or gold leaf.

100W E27  ●
20W E27  ●
60W E27  ●

1.30

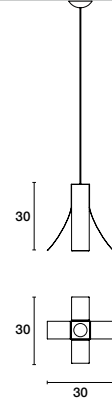

1 x  ● or 1 x  ●

SO 80

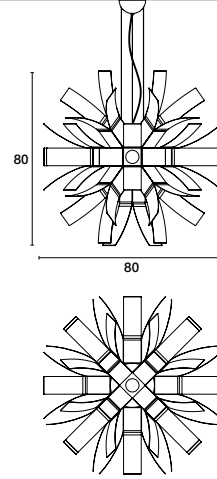

17 x  ● or 17 x  ●

PL 80

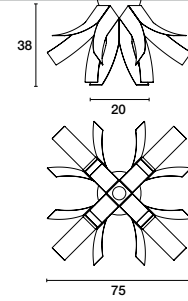

5 x  ● or 5 x  ●

1.45

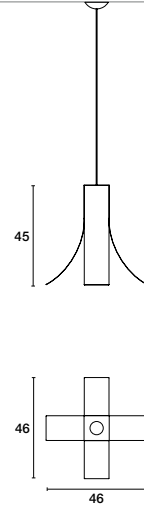

1 x  ● or 1 x  ●

SO 120

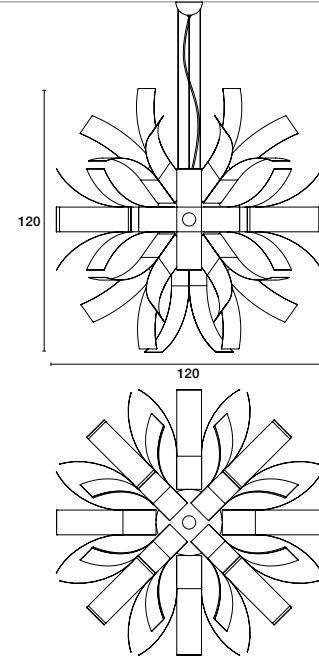

17 x  ● or 17 x  ●

PL 120

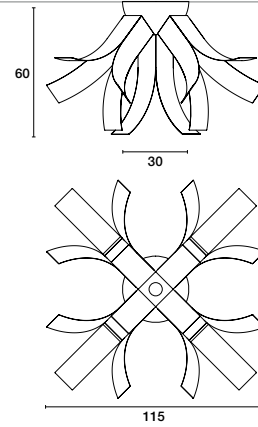

5 x  ● or 5 x  ●

LUCI IN SCENA

FOCUSING ON LIGHTS

Discovering paths, illuminating interiors,
mixing and interpreting traditions:
Façon de Venise brings light and character to any space.
Contamination, expression and composition:
just close your eyes for a new attractive setting.

LUCI IN SCENA

Percorsi da scoprire, ambienti da illuminare,
intrecci e rappresentazioni di storie:
Façon de Venise anima di luce e personalità ogni spazio.

Contaminazione, dialogo, composizione:
per una nuova suggestiva scena
ora basta solo chiudere gli occhi.

façon de venise by
LIGHT4

LIGHT4 srl viale dell'industria, 2A - 31055 quinto di treviso (tv) - italia
t. +39 0422 378122 - t. +39 0422 475009 - f +39 0422 370409
www.facondevenise.com - www.light4.it - info@light4.it

